

# MANDRINI TOOLHOLDERS





p. 020-022

## ISOCL

Calettamento a Caldo  
"Standard"  
Shrink Fit Holders  
"Standard"



NEW

p. 023-024

## ISOCLS

Calettamento a Caldo  
"Slim"  
Shrink Fit Holders  
"Slim"



p. 025-026

## ISOID

Serraggio Idraulico  
Hydraulic Chucks



p. 027-028

## ISOFS

Forte Serraggio  
Power Milling Chucks



NEW

p. 029-030

## ISOTF

Porta Testine Filettate  
(Tipo Conico)  
Screwed Milling Cutters  
(Tapered Type)



NEW

p. 031-032

## ISOTFC

Porta Testine Filettate  
(Tipo Cilindrico)  
Screwed Milling Cutters  
(Cylindrical Type)



p. 033-035

## ISOER

Portapinze ER  
(DIN 6499)  
Collet Chucks ER  
(DIN 6499)



NEW

p. 036-037

## ISOERM

Portapinze ER MINI  
(DIN 6499)  
Collet Chucks ER MINI  
(DIN 6499)



p. 038-039

## ISOOZ

Portapinze OZ  
(DIN 6388)  
Collet Chuck OZ  
(DIN 6388)



p. 040-044

## ISOWE

Attacco Weldon  
Weldon Holders



p. 045-046

## ISOWEG

Attacco Weldon con  
Canalini di Lubrificazione  
Weldon Holders with  
Coolant Grooves



p. 047-048

## ISOWN

Attacco Whistle Notch  
Whistle-Notch Holders



# SK - DIN 69871

Indice di sezione | Section Index



**p. 049-051**

## ISOFI

Portafrese Fissi  
(DIN 6357)  
Shell End Mill Holders  
(DIN 6357)



**p. 052-054**

## ISOAC

Portafrese Combinati  
(DIN 6358)  
Combi Shell End Mill Holders  
(DIN 6358)



**p. 055**

## ISOIX

Portapunte a  
Fissaggio Meccanico  
Indexable  
Drill Holders



**p. 056**

## ISOAS

Portapunte Autoserranti  
(Standard)  
Drill Chucks  
(Standard)



**p. 057-058**

## ISODS

Portapunte Autoserranti  
(Alta Precisione)  
Drill Chucks  
(High Precision)



**p. 059-062**

## ISOMS

Porta Maschi  
Tapping Chucks



**p. 062-063**

## ISOCM

Attacco Cono Morse  
per Punte (DIN 6383)  
Morse Taper  
for Drills (DIN 6383)



**p. 064-065**

## ISOMK

Attacco Cono Morse  
per Frese (DIN 6364)  
Morse Taper  
for End Mills (DIN 6364)



**p. 066**

## ISOD

Attacco Conico  
(DIN 238)  
Taper Shafts  
(DIN 238)



**NEW**

**p. 067**

## ISOMR

Mandrini di Riduzione  
Reduction Arbor



**NEW**

**p. 068**

## ISOSL

Semi Lavorato  
Blank Bars



**p. 069**

## ISOCK

Barre di Controllo  
Test Arbors

## ISOCL

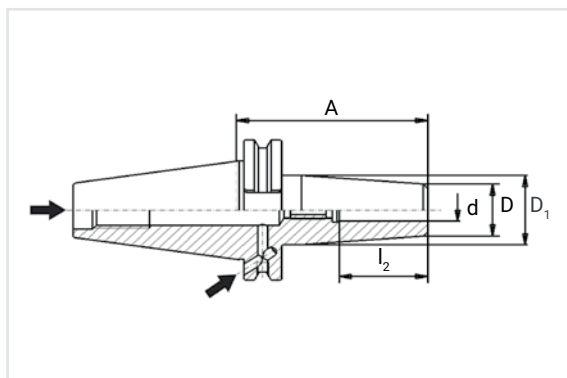
CALETTAMENTO A CALDO "STANDARD"  
SHRINK FIT HOLDERS "STANDARD"

## Dettagli tecnici | Technical details

Applicazione | Application

Per utensili con codolo cilindrico in tolleranza h6  
For tools with cylindrical shank with h6 tolerance

Forma | Form

AD/B

Grado di bilanciatura | Degree of balancing

G 2.5 20.000 giri/min | G 2.5 20.000 rpm

Run Out

Max. 3 µm

Accessori forniti | Accessories provided

-

Elenco Accessori e Ricambi a richiesta  
List of Accessories & Spare parts on request

Vedi pagina 22 | See page 22

Codice d'ordine  
Order Code

STATUS

## ISOCL 40

ISOCL 40X3X80	NEW ●
ISOCL 40X3X120	NEW ●
ISOCL 40X3X160	NEW ●
ISOCL 40X4X80	NEW ●
ISOCL 40X4X120	NEW ●
ISOCL 40X4X160	NEW ●
ISOCL 40X5X80	NEW ●

SK	d	A	l <sub>2</sub>	D	D <sub>1</sub>
40	3	80	-	12	20
40	3	120	-	12	20
40	3	160	-	12	20
40	4	80	-	15	25
40	4	120	-	15	25
40	4	160	-	15	25
40	5	80	-	15	25

La gamma prosegue nella pagina successiva | The range continues on the next page &gt;&gt;

Calettamento a Caldo "Standard" | Shrink Fit Holders "Standard"

Codice d'ordine Order Code	STATUS	SK	d	A	l <sub>2</sub>	D	D <sub>1</sub>
<b>ISOCL 40</b>							
ISOCL 40X5X120	NEW ●	40	5	120	-	15	25
ISOCL 40X5X160	NEW ●	40	5	160	-	15	25
ISOCL 40X6X80	●	40	6	80	36	20	27
ISOCL 40X6X120	NEW ●	40	6	120	36	21	27
ISOCL 40X6X160	●	40	6	160	36	21	27
ISOCL 40X8X80	●	40	8	80	36	20	27
ISOCL 40X8X120	NEW ●	40	8	120	36	21	27
ISOCL 40X8X160	●	40	8	160	36	21	27
ISOCL 40X10X80	●	40	10	80	42	24	32
ISOCL 40X10X120	NEW ●	40	10	120	42	24	32
ISOCL 40X10X160	●	40	10	160	42	24	32
ISOCL 40X12X80	●	40	12	80	47	24	32
ISOCL 40X12X120	NEW ●	40	12	120	47	24	32
ISOCL 40X12X160	●	40	12	160	47	24	32
ISOCL 40X14X80	●	40	14	80	47	27	34
ISOCL 40X14X120	NEW ●	40	14	120	47	27	34
ISOCL 40X14X160	●	40	14	160	47	27	34
ISOCL 40X16X80	●	40	16	80	50	27	34
ISOCL 40X16X120	NEW ●	40	16	120	50	27	34
ISOCL 40X16X160	●	40	16	160	50	27	34
ISOCL 40X18X80	●	40	18	80	50	33	42
ISOCL 40X18X120	NEW ●	40	18	120	50	33	42
ISOCL 40X18X160	●	40	18	160	50	33	42
ISOCL 40X20X80	●	40	20	80	52	33	42
ISOCL 40X20X120	NEW ●	40	20	120	52	33	42
ISOCL 40X20X160	●	40	20	160	52	33	42
ISOCL 40X25X100	●	40	25	100	58	44	53
ISOCL 40X25X160	●	40	25	160	58	44	53
ISOCL 40X32X100	●	40	32	100	58	44	53
ISOCL 40X32X160	●	40	32	160	58	44	53
<b>ISOCL 50</b>							
ISOCL 50X3X80	NEW ●	50	3	80	-	10	20
ISOCL 50X4X80	NEW ●	50	4	80	-	15	25
ISOCL 50X5X80	NEW ●	50	5	80	-	15	25
ISOCL 50X6X80	●	50	6	80	36	21	27
ISOCL 50X6X120	NEW ●	50	6	120	36	21	27
ISOCL 50X6X160	●	50	6	160	36	21	27
ISOCL 50X8X80	●	50	8	80	36	21	27
ISOCL 50X8X120	NEW ●	50	8	120	36	21	27
ISOCL 50X8X160	●	50	8	160	36	21	27
ISOCL 50X10X80	●	50	10	80	42	24	32

La gamma prosegue nella pagina successiva | The range continues on the next page >>

Codice d'ordine Order Code	STATUS	SK	d	A	l <sub>2</sub>	D	D <sub>1</sub>
<b>ISOCL 50</b>							
ISOCL 50X10X120	NEW ●	50	10	120	42	24	32
ISOCL 50X10X160	●	50	10	160	42	24	32
ISOCL 50X12X80	●	50	12	80	47	24	32
ISOCL 50X12X120	NEW ●	50	12	120	47	24	32
ISOCL 50X12X160	●	50	12	160	47	24	32
ISOCL 50X14X80	●	50	14	80	47	27	34
ISOCL 50X14X120	NEW ●	50	14	120	47	27	34
ISOCL 50X14X160	NEW ●	50	14	160	47	27	34
ISOCL 50X16X80	●	50	16	80	50	27	34
ISOCL 50X16X120	NEW ●	50	16	120	50	27	34
ISOCL 50X16X160	●	50	16	160	50	27	34
ISOCL 50X18X80	●	50	18	80	50	33	42
ISOCL 50X18X120	NEW ●	50	18	120	50	33	42
ISOCL 50X18X160	NEW ●	50	18	160	50	33	42
ISOCL 50X20X80	●	50	20	80	52	33	42
ISOCL 50X20X120	NEW ●	50	20	120	52	33	42
ISOCL 50X20X160	●	50	20	160	52	33	42
ISOCL 50X25X100	●	50	25	100	58	44	53
ISOCL 50X25X160	●	50	25	160	58	44	53
ISOCL 50X32X100	●	50	32	100	58	44	53
ISOCL 50X32X160	●	50	32	160	58	44	53

## Accessori e Ricambi | Accessories & Spare Parts

	Codice Code	Pagina Page
<b>01</b> PROLUNGHE PER CALETTAMENTO A CALDO   SHRINK FIT EXTENSIONS		
Standard	PRCL	p. 200
<b>02</b> TIRANTI - DIN 69872   PULL STUDS - DIN 69872		
Con foro di lubrificazione   With coolant bore	TRISOC	p. 262
Senza foro di lubrificazione   Without coolant bore	TRISOS	p. 263

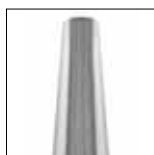

01



02

## ISOCLS

### CALETTAMENTO A CALDO "SLIM" SHRINK FIT HOLDERS "SLIM"

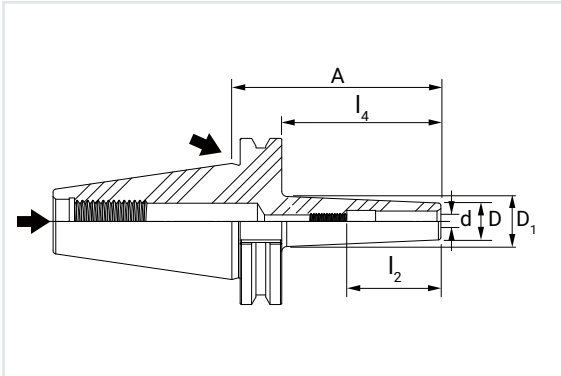

#### Dettagli tecnici | Technical details

Applicazione | Application

Forma | Form

Grado di bilanciatura | Degree of balancing

Run Out

Accessori forniti | Accessories provided

Elenco Accessori e Ricambi a richiesta  
List of Accessories & Spare parts on request

Per utensili con codolo cilindrico in tolleranza h6  
For tools with cylindrical shank with h6 tolerance

AD/B

G 2.5 25.000 giri/min | G 2.5 25.000 rpm

Max. 3 µm

Vedi pagina 24 | See page 24

Codice d'ordine  
Order Code

STATUS

#### ISOCLS 40

ISOCLS 40X6X80	NEW ●
ISOCLS 40X6X130	NEW ●
ISOCLS 40X6X160	NEW ●
ISOCLS 40X8X80	NEW ●
ISOCLS 40X8X130	NEW ●
ISOCLS 40X8X160	NEW ●
ISOCLS 40X10X80	NEW ●

SK	d	A	l <sub>2</sub>	l <sub>4</sub>	D	D <sub>1</sub>
40	6	80	36	60.9	12	17
40	6	130	36	110.9	12	19
40	6	160	36	140.9	12	19
40	8	80	36	60.9	14	19
40	8	130	36	110.9	14	21
40	8	160	36	140.9	14	21
40	10	80	42	60.9	16	21

La gamma prosegue nella pagina successiva | The range continues on the next page >>

Codice d'ordine Order Code	STATUS	SK	d	A	I <sub>2</sub>	I <sub>4</sub>	D	D <sub>1</sub>
<b>ISOCLS 40</b>								
ISOCLS 40X10X130	NEW ●	40	10	130	42	110.9	16	23
ISOCLS 40X10X160	NEW ●	40	10	160	42	140.9	16	23
ISOCLS 40X12X80	NEW ●	40	12	80	46	60.9	18	23
ISOCLS 40X12X130	NEW ●	40	12	130	46	110.9	18	25
ISOCLS 40X12X160	NEW ●	40	12	160	46	140.9	18	25
ISOCLS 40X14X80	NEW ●	40	14	80	46	60,9	20	25
ISOCLS 40X14X130	NEW ●	40	14	130	46	110,9	20	27
ISOCLS 40X14X160	NEW ●	40	14	160	46	140.9	20	27
ISOCLS 40X16X80	NEW ●	40	16	80	49	60.9	24	29
ISOCLS 40X16X130	NEW ●	40	16	130	49	110.9	24	31
ISOCLS 40X16X160	NEW ●	40	16	160	49	140.9	24	31
ISOCLS 40X20X80	NEW ●	40	20	80	51	60,9	28	33,5
ISOCLS 40X20X130	NEW ●	40	20	130	51	110,9	28	35
ISOCLS 40X20X160	NEW ●	40	20	160	51	140,9	28	35

### Accessori e Ricambi | Accessories & Spare Parts

	Codice Code	Pagina Page
<b>01 TIRANTI - DIN 69872   PULL STUDS - DIN 69872</b>		
Con foro di lubrificazione   With coolant bore	TRISOC	p. 262
Senza foro di lubrificazione   Without coolant bore	TRISOS	p. 263



01



## ISOID

### SERRAGGIO IDRAULICO HYDRAULIC CHUCKS

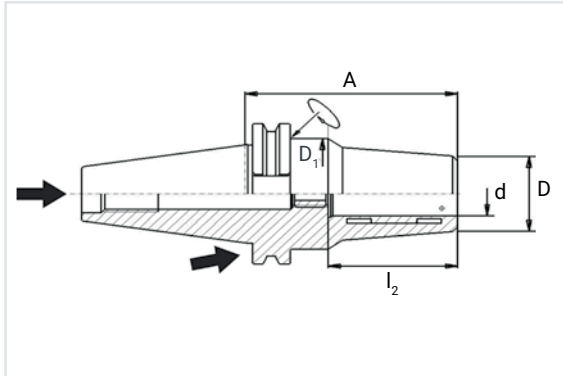

#### Dettagli tecnici | Technical details

Applicazione | Application

Per utensili con codolo cilindrico secondo norma DIN 6535 HA-HB, in tolleranza h6.  
For tools with cylindrical shank according to DIN 6535 HA-HB, with h6 tolerance.

Forma | Form

AD/B

Grado di bilanciatura | Degree of balancing

G 2.5 20.000 giri/min | G 2.5 20.000 rpm

Run Out

Max. 3  $\mu$ m

Accessori forniti | Accessories provided

Chiave | Wrench

Elenco Accessori e Ricambi a richiesta  
List of Accessories & Spare parts on request

Vedi pagina 26 | See page 26

Codice d'ordine  
Order Code

STATUS

#### ISOID 40

ISOID 40X12	●
ISOID 40X16	●
ISOID 40X20	●
ISOID 40X25	●
ISOID 40X32	●

SK	d	A	l <sub>2</sub>	D	D <sub>1</sub>
40	12	80	40	32	49,5
40	16	80	46	38	49,5
40	20	80	51	42	49,5
40	25	95	57	55	63
40	32	95	61	63	70

La gamma prosegue nella pagina successiva | The range continues on the next page >>

Codice d'ordine Order Code	STATUS	SK	d	A	l <sub>2</sub>	D	D <sub>1</sub>
<b>ISOID 50</b>							
ISOID 50X20	●	50	20	80	51	42	49,5
ISOID 50X25	●	50	25	100	57	55	63
ISOID 50X32	●	50	32	100	61	63	70
<b>ISOIDE 40</b> (Versione corta, idonea alle lavorazioni di sgrossatura pesante in fresatura   Short version, suitable for heavy roughing operations in milling)							
ISOIDE 40X20	●	40	20	64,5	51	41	49,5
<b>ISOIDE 50</b> (Versione corta, idonea alle lavorazioni di sgrossatura pesante in fresatura   Short version, suitable for heavy roughing operations in milling)							
ISOIDE 50X32	●	50	32	81	61	62	70

### Accessori e Ricambi | Accessories & Spare Parts

	Codice Code	Pagina Page
<b>01 PROLUNGHE PER CALETTAMENTO A CALDO   SHRINK FIT EXTENSIONS</b>		
Standard	PRCL	p. 200
<b>02 BUSSOLE DI RIDUZIONE   REDUCTION SLEEVE</b>		
Standard	BSID	p. 248
<b>03 TIRANTI - DIN 69872   PULL STUDS - DIN 69872</b>		
Con foro di lubrificazione   With coolant bore	TRISOC	p. 262
Senza foro di lubrificazione   Without coolant bore	TRISOS	p. 263

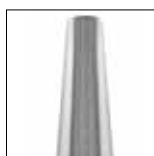

01



02



03

## ISOFS

### FORTE SERRAGGIO POWER MILLING CHUCKS

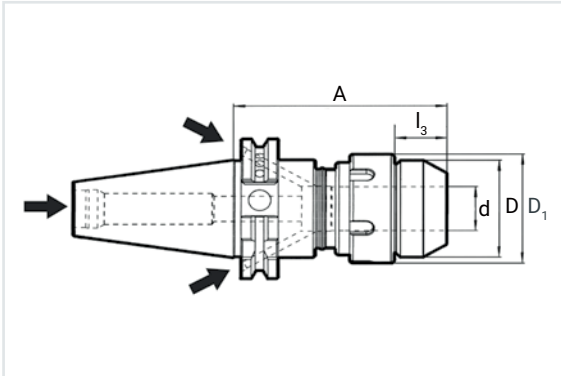

#### Dettagli tecnici | Technical details

Applicazione | Application

Forma | Form

Grado di bilanciatura | Degree of balancing

Run Out

Accessori forniti | Accessories provided

Elenco Accessori e Ricambi a richiesta  
List of Accessories & Spare parts on request

Per utensili con codolo cilindrico in differenti tolleranze  
For tools with cylindrical shank in different tolerances

AD/B

G 2.5 20.000 giri/min | G 2.5 20.000 rpm

Max. 4  $\mu\text{m}$  (3 x d)

Chiave | Wrench

Vedi pagina 28 | See page 28

Codice d'ordine  
Order Code

STATUS

#### ISOFS 40

ISOFS 40X20X90 ●

ISOFS 40X20X150 NEW ●

ISOFS 40X32X105 ●

#### ISOFS 50

ISOFS 50X20X90 ●

ISOFS 50X20X150 NEW ●

SK	d	A	$l_3$	D	$D_1$
----	---	---	-------	---	-------

40	20	90	23	46	49
----	----	----	----	----	----

40	20	150	23	46	49
----	----	-----	----	----	----

40	32	105	33	67	68
----	----	-----	----	----	----

50	20	90	23	46	49
----	----	----	----	----	----

50	20	150	33	67	68
----	----	-----	----	----	----

La gamma prosegue nella pagina successiva | The range continues on the next page >>

Codice d'ordine Order Code	STATUS	SK	d	A	I <sub>3</sub>	D	D <sub>1</sub>
<b>ISOFS 50</b>							
ISOFS 50X32X95	■	50	32	95	33	67	68
ISOFS 50X32X105	●	50	32	105	33	67	68

■ Fino ad esaurimento scorte | Till stocks last

### Forza e coppia di serraggio | Tightening force and torque

Diametro utensile Tool diameter	Coppia di serraggio massima Maximum tightening torque	Forza di serraggio Clamping force
6	60 Nm	150 Nm
8	60 Nm	180 Nm
10	80 Nm	320 Nm
12	80 Nm	380 Nm
16	100 Nm	400 Nm
20	100 Nm	520 Nm
25	150 Nm	550 Nm
32	150 Nm	800 Nm

Esempio: Il mandrino deve essere bloccato tramite una chiave dinamometrica con coppia di serraggio massima di 60 Nm per raggiungere una forza di serraggio sul codolo alloggiato di 150 Nm.

Example: you should clamp the chuck with a tightening-torque-wrench with the maximum tightening torque of 60 Nm (maximum), to reach a clamping force on the clamped shaft of 150 Nm.

### Accessori e Ricambi | Accessories & Spare Parts

	Codice Code	Pagina Page
<b>01 BUSSOLE DI RIDUZIONE   REDUCTION SLEEVE</b>		
Standard	BSFS	p. 246
<b>02 TIRANTI - DIN 69872   PULL STUDS - DIN 69872</b>		
Con foro di lubrificazione   With coolant bore	TRISOC	p. 262
Senza foro di lubrificazione   Without coolant bore	TRISOS	p. 263



01



02

## ISOTF

### PORTA TESTINE FILETTATE (TIPO CONICO) SCREWED MILLING CUTTERS (TAPERED TYPE)

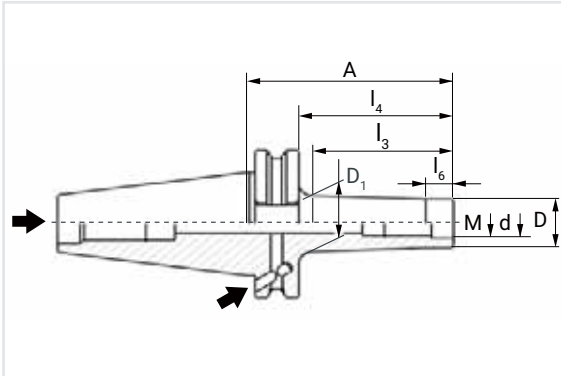

#### Dettagli tecnici | Technical details

Applicazione | Application

Per frese con attacco filettato  
For end mills with threaded shank

Forma | Form

AD/B

Grado di bilanciatura | Degree of balancing

G 6.3 15.000 giri/min | G 6.3 15.000 rpm

Run Out

-

Accessori forniti | Accessories provided

-

Elenco Accessori e Ricambi a richiesta  
List of Accessories & Spare parts on request

Vedi pagina 32 | See page 32

Codice d'ordine  
Order Code

STATUS

SK d A M I<sub>3</sub> I<sub>4</sub> I<sub>6</sub> D D<sub>1</sub>

#### ISOTF 40

ISOTF 40XM6X44	NEW ●	40	6,5	44	M 6	20	25	-	10	13
ISOTF 40XM6X69	NEW ●	40	6,5	69	M 6	46	50	-	10	20
ISOTF 40XM6X94	NEW ●	40	6,5	94	M 6	70	75	-	10	23
ISOTF 40XM8X44	NEW ●	40	8,5	44	M 8	24	25	10	13	18
ISOTF 40XM8X69	NEW ●	40	8,5	69	M 8	48	50	10	13	23
ISOTF 40XM8X94	NEW ●	40	8,5	94	M 8	65	75	10	13	20
ISOTF 40XM8X119	NEW ●	40	8,5	119	M 8	90	100	10	13	22

La gamma prosegue nella pagina successiva | The range continues on the next page >>

Codice d'ordine Order Code	STATUS	SK	d	A	M	l <sub>3</sub>	l <sub>4</sub>	l <sub>6</sub>	D	D <sub>1</sub>
<b>ISOTF 40</b>										
ISOTF 40XM10X44	NEW ●	40	10,5	44	M 10	24	25	10	18	20
ISOTF 40XM10X69	NEW ●	40	10,5	69	M 10	48	50	10	18	23
ISOTF 40XM10X94	NEW ●	40	10,5	94	M 10	73	75	10	18	28
ISOTF 40XM10X119	NEW ●	40	10,5	119	M 10	90	100	10	18	29
ISOTF 40XM12X44	NEW ●	40	12,5	44	M 12	24	25	10	21	24
ISOTF 40XM12X69	NEW ●	40	12,5	69	M 12	48	50	10	21	24
ISOTF 40XM12X94	NEW ●	40	12,5	94	M 12	73	75	10	21	31
ISOTF 40XM12X119	NEW ●	40	12,5	119	M 12	90	100	10	21	32
ISOTF 40XM12X144	NEW ●	40	12,5	144	M 12	123	125	10	21	36
ISOTF 40XM12X169	NEW ●	40	12,5	169	M 12	146	150	10	21	40
ISOTF 40XM16X44	NEW ●	40	17	44	M 16	23	25	10	29	29
ISOTF 40XM16X69	NEW ●	40	17	69	M 16	48	50	10	29	34
ISOTF 40XM16X94	NEW ●	40	17	94	M 16	73	75	10	29	35
ISOTF 40XM16X119	NEW ●	40	17	119	M 16	90	100	10	29	36
ISOTF 40XM16X144	NEW ●	40	17	144	M 16	123	125	10	29	40
ISOTF 40XM16X169	NEW ●	40	17	169	M 16	142	150	10	29	43
<b>ISOTF 50</b>										
ISOTF 50XM8X69	NEW ●	50	8,5	69	M 8	48	50	10	13	23
ISOTF 50XM8X119	NEW ●	50	8,5	119	M 8	90	100	10	13	23
ISOTF 50XM8X169	NEW ●	50	8,5	169	M 8	130	150	10	13	27
ISOTF 50XM10X69	NEW ●	50	10,5	69	M 10	48	50	10	18	23
ISOTF 50XM10X119	NEW ●	50	10,5	119	M 10	98	100	10	18	32
ISOTF 50XM10X169	NEW ●	50	10,5	169	M 10	130	150	10	18	32
ISOTF 50XM12X69	NEW ●	50	12,5	69	M 12	42	50	10	21	24
ISOTF 50XM12X119	NEW ●	50	12,5	119	M 12	90	100	10	21	32
ISOTF 50XM12X169	NEW ●	50	12,5	169	M 12	147	150	10	21	40
ISOTF 50XM16X69	NEW ●	50	17	69	M 16	42	50	10	29	34
ISOTF 50XM16X119	NEW ●	50	17	119	M 16	95	100	10	29	36
ISOTF 50XM16X169	NEW ●	50	17	169	M 16	130	150	10	29	40

## ISOTFC

### PORTA TESTINE FILETTATE (TIPO CILINDRICO) SCREWED MILLING CUTTERS (CYLINDRICAL TYPE)

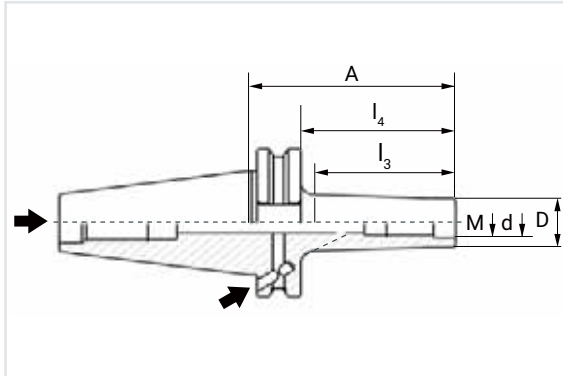

#### Dettagli tecnici | Technical details

Applicazione | Application

Per frese con attacco filettato  
For end mills with threaded shank

Forma | Form

AD/B

Grado di bilanciatura | Degree of balancing

G 6.3 15.000 giri/min | G 6.3 15.000 rpm

Run Out

-

Accessori forniti | Accessories provided

-

Elenco Accessori e Ricambi a richiesta  
List of Accessories & Spare parts on request

Vedi pagina 32 | See page 32

Codice d'ordine  
Order Code

STATUS

#### ISOTFC 40

ISOTFC 40XM10X69	NEW ●
ISOTFC 40XM10X94	NEW ●
ISOTFC 40XM10X119	NEW ●
ISOTFC 40XM12X69	NEW ●
ISOTFC 40XM12X94	NEW ●
ISOTFC 40XM12X119	NEW ●
ISOTFC 40XM12X144	NEW ●

SK	d	A	M	I <sub>3</sub>	I <sub>4</sub>	D
40	10,5	69	M 10	42	50	18
40	10,5	94	M 10	65	75	18
40	10,5	119	M 10	85	100	18
40	12,5	69	M 12	44	50	21
40	12,5	94	M 12	65	75	21
40	12,5	119	M 12	85	100	21
40	12,5	144	M 12	110	125	21

La gamma prosegue nella pagina successiva | The range continues on the next page >>

Codice d'ordine Order Code	STATUS	SK	d	A	M	I <sub>3</sub>	I <sub>4</sub>	D
<b>ISOTFC 40</b>								
ISOTFC 40XM12X169	NEW ●	40	12,5	169	M 12	132	150	21
ISOTFC 40XM16X69	NEW ●	40	17	69	M 16	44	50	29
ISOTFC 40XM16X94	NEW ●	40	17	94	M 16	68	75	29
ISOTFC 40XM16X119	NEW ●	40	17	119	M 16	90	100	29
ISOTFC 40XM16X144	NEW ●	40	17	144	M 16	110	125	29
ISOTFC 40XM16X169	NEW ●	40	17	169	M 16	130	150	29
<b>ISOTFC 50</b>								
ISOTFC 50XM10X119	NEW ●	50	10,5	119	M 10	85	100	18
ISOTFC 50XM10X169	NEW ●	50	10,5	169	M 10	135	150	18
ISOTFC 50XM12X119	NEW ●	50	12,5	119	M 12	85	100	21
ISOTFC 50XM12X169	NEW ●	50	12,5	169	M 12	135	150	21
ISOTFC 50XM16X119	NEW ●	50	17	119	M 16	90	100	29
ISOTFC 50XM16X169	NEW ●	50	17	169	M 16	140	150	29

### Accessori e Ricambi (ISOTF - ISOTFC) | Accessories & Spare Parts (ISOTF - ISOTFC)

	Codice Code	Pagina Page
<b>01 TIRANTI - DIN 69872   PULL STUDS - DIN 69872</b>		
Con foro di lubrificazione   With coolant bore	TRISOC	p. 262
Senza foro di lubrificazione   Without coolant bore	TRISOS	p. 263
<b>02 PROLUNGHE PER PORTA TESTINE FILETTATE   EXTENSIONS FOR SCREWED MILLING CUTTERS</b>		
Standard	PRTF	p. 210
<b>03 RIDUZIONI PER PORTA TESTINE FILETTATE   REDUCTIONS FOR SCREWED MILLING CUTTERS</b>		
Standard	RTF	p. 283



01



02



03



## ISOERAD - ISOER

### PORTAPINZE ER (DIN 6499) COLLET CHUCKS ER (DIN 6499)

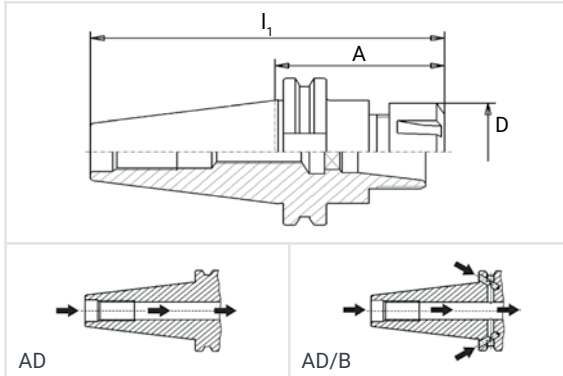

#### Dettagli tecnici | Technical details

Applicazione | Application

Forma | Form

Grado di bilanciatura | Degree of balancing

Run Out

Accessori forniti | Accessories provided

Elenco Accessori e Ricambi a richiesta  
List of Accessories & Spare parts on request

Per utensili con codolo cilindrico in differenti tolleranze  
For tools with cylindrical shank in different tolerances

AD - AD/B

G 6.3 15.000 giri/min | G 6.3 15.000 rpm

Max. 5 µm

Ghiera di bloccaggio standard | Standard clamp nut

Vedi pagina 35 | See page 35

Codice d'ordine  
Order Code

STATUS

#### ISOERAD 30

ISOERAD 30X16X70	NEW ●
ISOERAD 30X16X100	NEW ●
ISOERAD 30X25X70	NEW ●
ISOERAD 30X25X100	NEW ●
ISOERAD 30X32X70	NEW ●
ISOERAD 30X32X100	NEW ●

SK	ER	A	L <sub>1</sub>	D	Forma Form
30	16	70	118	32	AD
30	16	100	148	32	AD
30	25	70	118	42	AD
30	25	100	148	42	AD
30	32	70	118	50	AD
30	32	100	148	50	AD

La gamma prosegue nella pagina successiva | The range continues on the next page >>

Ordine d'ordine Order Code	STATUS	SK	ER	A	I <sub>1</sub>	D	Forma Form
<b>ISOERAD 40</b>							
ISOERAD 40X16X63	NEW ●	40	16	63	132	32	AD
ISOERAD 40X16X100	NEW ●	40	16	100	169	32	AD
ISOERAD 40X25X60	NEW ●	40	25	60	129	42	AD
ISOERAD 40X25X100	NEW ●	40	25	100	169	42	AD
ISOERAD 40X32X70	NEW ●	40	32	70	139	50	AD
ISOERAD 40X32X100	NEW ●	40	32	100	169	50	AD
ISOERAD 40X40X80	NEW ●	40	40	80	149	63	AD
ISOERAD 40X40X120	NEW ●	40	40	120	189	63	AD
<b>ISOERAD 50</b>							
ISOERAD 50X25X60	NEW ●	50	25	60	162	42	AD
ISOERAD 50X25X100	NEW ●	50	25	100	202	42	AD
ISOERAD 50X32X70	NEW ●	50	32	70	172	50	AD
ISOERAD 50X32X100	NEW ●	50	32	100	202	50	AD
ISOERAD 50X40X80	NEW ●	50	40	80	182	63	AD
ISOERAD 50X40X100	NEW ●	50	40	100	202	63	AD
<b>ISOER 40</b>							
ISOER 40X16X63	●	40	16	63	132	32	AD/B
ISOER 40X16X100	●	40	16	100	169	32	AD/B
ISOER 40X16X160	●	40	16	160	229	32	AD/B
ISOER 40X16X200	●	40	16	200	269	32	AD/B
ISOER 40X25X60	●	40	25	60	129	42	AD/B
ISOER 40X25X100	●	40	25	100	169	42	AD/B
ISOER 40X25X160	●	40	25	160	229	42	AD/B
ISOER 40X25X200	●	40	25	200	269	42	AD/B
ISOER 40X32X70	●	40	32	70	139	50	AD/B
ISOER 40X32X100	●	40	32	100	169	50	AD/B
ISOER 40X32X120	●	40	32	120	189	50	AD/B
ISOER 40X32X160	●	40	32	160	229	50	AD/B
ISOER 40X32X200	●	40	32	200	269	50	AD/B
ISOER 40X40X80	●	40	40	80	149	63	AD/B
ISOER 40X40X120	●	40	40	120	189	63	AD/B
ISOER 40X40X160	●	40	40	160	229	63	AD/B
<b>ISOER 50</b>							
ISOER 50X16X100	●	50	16	100	202	32	AD/B
ISOER 50X16X160	●	50	16	160	262	32	AD/B
ISOER 50X16X200	●	50	16	200	302	32	AD/B
ISOER 50X25X60	●	50	25	60	162	42	AD/B
ISOER 50X25X100	●	50	25	100	202	42	AD/B
ISOER 50X25X160	●	50	25	160	262	42	AD/B

La gamma prosegue nella pagina successiva | The range continues on the next page &gt;&gt;

Codice d'ordine Order Code	STATUS	SK	ER	A	I <sub>1</sub>	D	Forma Form
<b>ISOER 50</b>							
ISOER 50X25X200	●	50	25	200	302	42	AD/B
ISOER 50X32X70	●	50	32	70	172	50	AD/B
ISOER 50X32X100	●	50	32	100	202	50	AD/B
ISOER 50X32X160	●	50	32	160	262	50	AD/B
ISOER 50X32X200	●	50	32	200	302	50	AD/B
ISOER 50X40X80	●	50	40	80	182	63	AD/B
ISOER 50X40X100	●	50	40	100	202	63	AD/B
ISOER 50X40X160	●	50	40	160	262	63	AD/B
ISOER 50X50X100	●	50	50	100	202	78	AD/B

## Accessori e Ricambi | Accessories & Spare Parts

	Codice Code	Pagina Page
<b>01 PINZE ER   ER COLLETS</b>		
Standard	PZER	p. 216
Ultra precise   High precision	ERUP	p. 223
Vulcanizzate   Rubber sealed collets	ERVU	p. 229
Con quadro interno   With internal square	PZSQ	p. 233
A tenuta con fori di lubrificazione   Externally cooled collets	PZERJ	p. 236
<b>02 GHIERA DI BLOCCAGGIO ER   ER CLAMP NUT</b>		
Standard	GRERB	p. 256
Bilanciata   Balanced	GRERC	p. 256
Per forte serraggio   For high clamping power	GRERD	p. 257
Con anello di tenuta   With sealing disk	GRERE	p. 257
Con anello di tenuta a step di 0.5 mm   With sealing disk in 0.5 mm steps	GRERF	p. 257
<b>03 CHIAVE DI BLOCCAGGIO ER   ER WRENCH CLAMP</b>		
Standard	CVER	p. 277
<b>04 TIRANTI - DIN 69872   PULL STUDS - DIN 69872</b>		
Con foro di lubrificazione   With coolant bore	TRISOC	p. 262
Senza foro di lubrificazione   Without coolant bore	TRISOS	p. 263
<b>05 PROLUNGHE CILINDRICHE PER PORTA PINZE ER   CYLINDRICAL EXTENSIONS FOR ER COLLET CHUCKS</b>		
Standard	PGCL	p. 202



01



02



03



04



05

## ISOERM

### PORTAPINZE ER MINI (DIN 6499) COLLET CHUCKS ER MINI (DIN 6499)

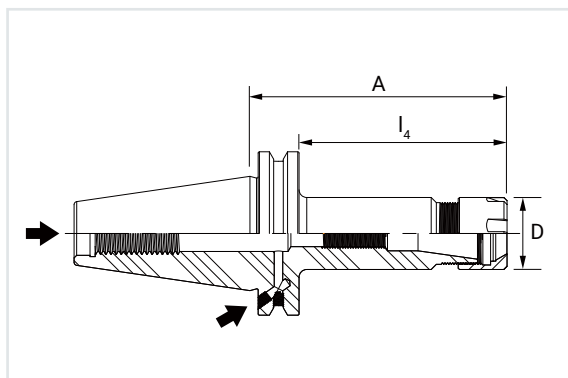

#### Dettagli tecnici | Technical details

Applicazione | Application

Per utensili con codolo cilindrico in differenti tolleranze  
For tools with cylindrical shank in different tolerances

Forma | Form

AD/B

Grado di bilanciatura | Degree of balancing

G 6.3 15.000 giri/min | G 6.3 15.000 rpm

Run Out

Max. 3 µm

Accessori forniti | Accessories provided

Ghiera di bloccaggio mini | Mini clamp nut

Elenco Accessori e Ricambi a richiesta  
List of Accessories & Spare parts on request

Vedi pagina 37 | See page 37

Codice d'ordine  
Order Code

STATUS

SK

ER

A

I<sub>4</sub>

D

#### ISOERM 40

ISOERM 40X8X130	NEW ●
ISOERM 40X8X160	NEW ●
ISOERM 40X11X80	NEW ●
ISOERM 40X11X100	NEW ●
ISOERM 40X11X125	NEW ●
ISOERM 40X11X150	NEW ●
ISOERM 40X16X70	NEW ●

40	8	130	110.9	12
40	8	160	140.9	12
40	11	80	60.9	16
40	11	100	80.9	16
40	11	125	105.9	16
40	11	150	130.9	16
40	16	70	50.9	22

La gamma prosegue nella pagina successiva | The range continues on the next page >>

Codice d'ordine Order Code	STATUS	SK	ER	A	I <sub>4</sub>	D
<b>ISOERM 40</b>						
ISOERM 40X16X100	NEW ●	40	16	100	80.9	22
ISOERM 40X16X125	NEW ●	40	16	125	105.9	22
ISOERM 40X16X150	NEW ●	40	16	150	130.9	22
ISOERM 40X16X200	NEW ●	40	16	200	180,9	22
ISOERM 40X20X100	NEW ●	40	20	100	80.9	28
ISOERM 40X20X130	NEW ●	40	20	130	115.9	28
ISOERM 40X20X150	NEW ●	40	20	150	130.9	28
ISOERM 40X20X200	NEW ●	40	20	200	180,9	28
ISOERM 40X25X100	NEW ●	40	25	100	80,9	35
ISOERM 40X25X125	NEW ●	40	25	125	105,9	35
ISOERM 40X25X150	NEW ●	40	25	150	130,9	35
ISOERM 40X25X200	NEW ●	40	25	200	180,9	35
<b>ISOERM 50</b>						
ISOERM 50X16X130	NEW ●	50	16	130	110.9	22
ISOERM 50X16X160	NEW ●	50	16	160	140.9	22
ISOERM 50X16X200	NEW ●	50	16	200	180.9	22

## Accessori e Ricambi | Accessories & Spare Parts

	Codice Code	Pagina Page
<b>01 PINZE ER   ER COLLETS</b>		
Standard	PZER	p. 216
Ultra precise   High precision	ERUP	p. 223
Vulcanizzate   Rubber sealed collets	ERVU	p. 229
Con quadro interno   With internal square	PZSQ	p. 233
A tenuta con fori di lubrificazione   Externally cooled collets	PZERJ	p. 236
<b>02 GHIERA DI BLOCCAGGIO ER   ER CLAMP NUT</b>		
Mini	GRERA	p. 256
<b>03 CHIAVE DI BLOCCAGGIO ER   ER WRENCH CLAMP</b>		
Mini	CVERM	p. 277
<b>04 TIRANTI - DIN 69872   PULL STUDS - DIN 69872</b>		
Con foro di lubrificazione   With coolant bore	TRISOC	p. 262
Senza foro di lubrificazione   Without coolant bore	TRISOS	p. 263
<b>05 PROLUNGHE PER PORTA PINZE ER (MINI)   EXTENSIONS FOR ER COLLET CHUCKS (MINI)</b>		
Prolunghe Cilindriche   Cylindrical Extensions	PGCLM	p. 204
Prolunghe Weldon   Weldon Extensions	PGWEM	p. 208

## ISO0Z

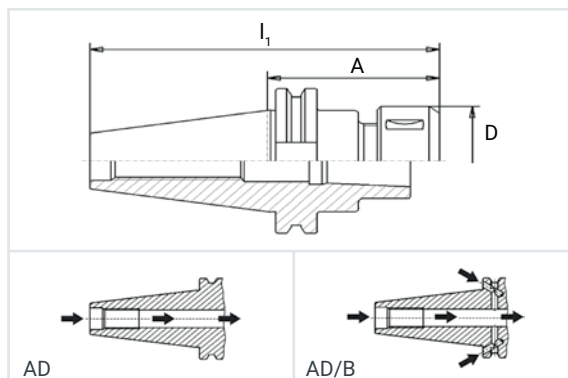
PORTAPINZE OZ (DIN 6388)  
COLLET CHUCKS OZ (DIN 6388)

## Dettagli tecnici | Technical details

Applicazione | Application

Per utensili con codolo cilindrico in differenti tolleranze  
For tools with cylindrical shank in different tolerances

Forma | Form

AD - AD/B

Grado di bilanciatura | Degree of balancing

G 6.3 15.000 giri/min | G 6.3 15.000 rpm

Run Out

Max. 5 µm

Accessori forniti | Accessories provided

Ghiera di bloccaggio standard | Standard clamp nut

Elenco Accessori e Ricambi a richiesta  
List of Accessories & Spare parts on request

Vedi pagina 39 | See page 39

Codice d'ordine  
Order Code

STATUS

SK OZ A L<sub>1</sub> D Forma  
Form

## ISO0Z 30

ISO0Z 30X16X60	●
ISO0Z 30X25X80	●

30	16	60	108	43	AD
30	25	80	128	60	AD

## ISO0Z 40

ISO0Z 40X16X70	●
ISO0Z 40X25X70	●
ISO0Z 40X25X100	●

40	16	70	138	43	AD/B
40	25	70	138	60	AD/B
40	25	100	168	60	AD/B

La gamma prosegue nella pagina successiva | The range continues on the next page &gt;&gt;

Codice d'ordine Order Code	STATUS	SK	OZ	A	I <sub>1</sub>	D	Forma Form
<b>ISOZ 40</b>							
ISOZ 40X32X90	●	40	32	90	158	72	AD/B
<b>ISOZ 50</b>							
ISOZ 50X25X70	●	50	25	70	172	60	AD/B
ISOZ 50X32X80	●	50	32	80	182	72	AD/B

## Accessori e Ricambi | Accessories & Spare Parts

	Codice Code	Pagina Page
<b>01 PINZE OZ   OZ COLLETS</b>		
Standard	PZOZ	p. 239
<b>02 GHIERA DI BLOCCAGGIO OZ   OZ CLAMP NUT</b>		
Standard	GRID1	p. 258
Bilanciato   Balanced	GRID2	p. 258
Con canali di lubrificazione   With coolant channels	GRID3	p. 258
Con anello di tenuta   With sealing disk	GRID4	p. 258
<b>03 CHIAVE DI BLOCCAGGIO OZ   OZ WRENCH CLAMP</b>		
Standard	CVOZ	p. 278
<b>04 TIRANTI - DIN 69872   PULL STUDS - DIN 69872</b>		
Con foro di lubrificazione   With coolant bore	TRISOC	p. 262
Senza foro di lubrificazione   Without coolant bore	TRISOS	p. 263
<b>05 PROLUNGHE CILINDRICHE PER PORTA PINZE ER   CYLINDRICAL EXTENSIONS FOR ER COLLET CHUCKS</b>		
Standard	PGCL	p. 202



01



02



03



04



05

## ISOWEAD-ISOWE

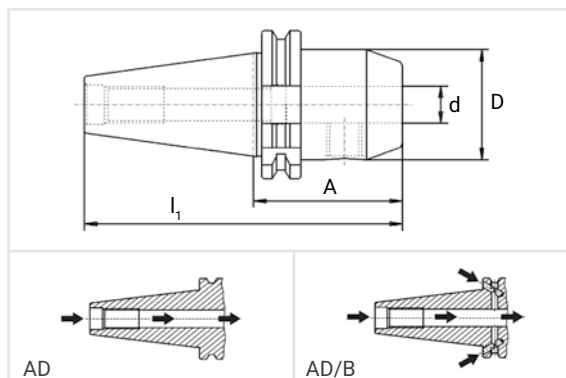
ATTACCO WELDON  
WELDON HOLDERS

## Dettagli tecnici | Technical details

Applicazione | Application

Per utensili con codolo cilindrico tipo weldon secondo norma DIN 1835B  
For tools with weldon type cylindrical shank according to DIN 1835B

Forma | Form

AD - AD/B

Grado di bilanciatura | Degree of balancing

G 6.3 15.000 giri/min | G 6.3 15.000 rpm

Run Out

Max. 15 µm (3 x d)

Accessori forniti | Accessories provided

Vite di bloccaggio | Clamping screw

Elenco Accessori e Ricambi a richiesta  
List of Accessories & Spare parts on request

Vedi pagina 44 | See page 44

Codice d'ordine  
Order Code

STATUS

SK

d

A

l<sub>1</sub>

D

Forma  
Form

## ISOWEAD 30

ISOWEAD 30X6X50	●
ISOWEAD 30X8X50	●
ISOWEAD 30X10X50	●
ISOWEAD 30X12X50	●
ISOWEAD 30X14X50	●
ISOWEAD 30X16X63	●
ISOWEAD 30X20X63	●

SK	d	A	l <sub>1</sub>	D	Forma Form
30	6	50	98	25	AD
30	8	50	98	28	AD
30	10	50	98	35	AD
30	12	50	98	42	AD
30	14	50	98	42	AD
30	16	63	111	48	AD
30	20	63	111	52	AD

La gamma prosegue nella pagina successiva | The range continues on the next page &gt;&gt;



Codice d'ordine Order Code	STATUS	SK	d	A	l <sub>1</sub>	D	Forma Form
<b>ISOWEAD 40</b>							
ISOWEAD 40X6X50	NEW ●	40	6	50	118	25	AD
ISOWEAD 40X6X100	NEW ●	40	6	100	168	25	AD
ISOWEAD 40X8X50	NEW ●	40	8	50	118	28	AD
ISOWEAD 40X8X100	NEW ●	40	8	100	168	28	AD
ISOWEAD 40X10X50	NEW ●	40	10	50	118	35	AD
ISOWEAD 40X10X100	NEW ●	40	10	100	168	35	AD
ISOWEAD 40X12X50	NEW ●	40	12	50	118	42	AD
ISOWEAD 40X12X100	NEW ●	40	12	100	168	42	AD
ISOWEAD 40X14X50	NEW ●	40	14	50	118	42	AD
ISOWEAD 40X16X35	NEW ●	40	16	35	103	48	AD
ISOWEAD 40X16X63	NEW ●	40	16	63	131	48	AD
ISOWEAD 40X16X100	NEW ●	40	16	100	168	48	AD
ISOWEAD 40X18X63	NEW ●	40	18	63	131	48	AD
ISOWEAD 40X20X35	NEW ●	40	20	35	103	44,45	AD
ISOWEAD 40X20X63	NEW ●	40	20	63	131	52	AD
ISOWEAD 40X20X100	NEW ●	40	20	100	168	52	AD
ISOWEAD 40X25X35	NEW ●	40	25	35	103	44,45	AD
ISOWEAD 40X25X100	NEW ●	40	25	100	168	63	AD
ISOWEAD 40X32X100	NEW ●	40	32	100	168	70	AD
ISOWEAD 40X40X120	NEW ●	40	40	120	188	80	AD
<b>ISOWEAD 50</b>							
ISOWEAD 50X6X63	NEW ●	50	6	63	165	25	AD
ISOWEAD 50X6X100	NEW ●	50	6	100	202	25	AD
ISOWEAD 50X8X63	NEW ●	50	8	63	165	28	AD
ISOWEAD 50X8X100	NEW ●	50	8	100	202	28	AD
ISOWEAD 50X10X63	NEW ●	50	10	63	165	35	AD
ISOWEAD 50X10X100	NEW ●	50	10	100	202	35	AD
ISOWEAD 50X12X63	NEW ●	50	12	63	165	42	AD
ISOWEAD 50X12X100	NEW ●	50	12	100	202	42	AD
ISOWEAD 50X14X63	NEW ●	50	14	63	165	42	AD
ISOWEAD 50X16X63	NEW ●	50	16	63	165	48	AD
ISOWEAD 50X16X100	NEW ●	50	16	100	202	48	AD
ISOWEAD 50X18X63	NEW ●	50	18	63	165	48	AD
ISOWEAD 50X20X63	NEW ●	50	20	63	165	52	AD
ISOWEAD 50X20X100	NEW ●	50	20	100	202	52	AD
ISOWEAD 50X25X80	NEW ●	50	25	80	182	63	AD
ISOWEAD 50X32X100	NEW ●	50	32	100	202	70	AD
ISOWEAD 50X40X100	NEW ●	50	40	100	202	80	AD
<b>ISOWE 40</b>							
ISOWE 40X6X50	●	40	6	50	118	25	AD/B

La gamma prosegue nella pagina successiva | The range continues on the next page &gt;&gt;

Codice d'ordine Order Code	STATUS	SK	d	A	l <sub>1</sub>	D	Forma Form
<b>ISOWE 40</b>							
ISOWE 40X6X100	●	40	6	100	168	25	AD/B
ISOWE 40X6X160	●	40	6	160	228	25	AD/B
ISOWE 40X6X200	●	40	6	200	268	25	AD/B
ISOWE 40X8X50	●	40	8	50	118	28	AD/B
ISOWE 40X8X100	●	40	8	100	168	28	AD/B
ISOWE 40X8X160	●	40	8	160	228	28	AD/B
ISOWE 40X8X200	●	40	8	200	268	28	AD/B
ISOWE 40X10X50	●	40	10	50	118	35	AD/B
ISOWE 40X10X100	●	40	10	100	168	35	AD/B
ISOWE 40X10X160	●	40	10	160	228	35	AD/B
ISOWE 40X10X200	●	40	10	200	268	35	AD/B
ISOWE 40X12X50	●	40	12	50	118	42	AD/B
ISOWE 40X12X100	●	40	12	100	168	42	AD/B
ISOWE 40X12X160	●	40	12	160	228	42	AD/B
ISOWE 40X12X200	●	40	12	200	268	42	AD/B
ISOWE 40X14X50	●	40	14	50	118	42	AD/B
ISOWE 40X14X100	●	40	14	100	168	42	AD/B
ISOWE 40X14X160	●	40	14	160	228	42	AD/B
ISOWE 40X14X200	NEW ●	40	14	200	268	42	AD/B
ISOWE 40X16X63	●	40	16	63	131	48	AD/B
ISOWE 40X16X100	●	40	16	100	168	48	AD/B
ISOWE 40X16X160	●	40	16	160	228	48	AD/B
ISOWE 40X16X200	NEW ●	40	16	200	268	48	AD/B
ISOWE 40X18X63	●	40	18	63	131	48	AD/B
ISOWE 40X18X100	●	40	18	100	168	48	AD/B
ISOWE 40X18X160	●	40	18	160	228	48	AD/B
ISOWE 40X18X200	NEW ●	40	18	200	268	48	AD/B
ISOWE 40X20X35	NEW ●	40	20	35	103	44,45	AD/B
ISOWE 40X20X63	●	40	20	63	131	52	AD/B
ISOWE 40X20X100	●	40	20	100	168	52	AD/B
ISOWE 40X20X160	●	40	20	160	228	52	AD/B
ISOWE 40X20X200	●	40	20	200	268	52	AD/B
ISOWE 40X22X63	NEW ●	40	22	63	131	52	AD/B
ISOWE 40X25X35	●	40	25	35	103	44,45	AD/B
ISOWE 40X25X100	●	40	25	100	168	63	AD/B
ISOWE 40X25X160	●	40	25	160	228	63	AD/B
ISOWE 40X25X200	●	40	25	200	268	63	AD/B
ISOWE 40X32X63	NEW ●	40	32	63	131	50	AD/B
ISOWE 40X32X100	●	40	32	100	168	70	AD/B
ISOWE 40X32X160	●	40	32	160	228	70	AD/B
ISOWE 40X32X200	NEW ●	40	32	200	268	70	AD/B
ISOWE 40X40X120	●	40	40	120	188	80	AD/B

La gamma prosegue nella pagina successiva | The range continues on the next page &gt;&gt;

Codice d'ordine Order Code	STATUS	SK	d	A	I <sub>1</sub>	D	Forma Form
<b>ISOWE 50</b>							
ISOWE 50X6X63	●	50	6	63	165	25	AD/B
ISOWE 50X6X100	●	50	6	100	202	25	AD/B
ISOWE 50X6X160	●	50	6	160	262	25	AD/B
ISOWE 50X6X200	NEW ●	50	6	200	302	25	AD/B
ISOWE 50X8X63	●	50	8	63	165	28	AD/B
ISOWE 50X8X100	●	50	8	100	202	28	AD/B
ISOWE 50X8X160	●	50	8	160	262	28	AD/B
ISOWE 50X8X200	●	50	8	200	302	28	AD/B
ISOWE 50X10X63	●	50	10	63	165	35	AD/B
ISOWE 50X10X100	●	50	10	100	202	35	AD/B
ISOWE 50X10X160	●	50	10	160	262	35	AD/B
ISOWE 50X10X200	●	50	10	200	302	35	AD/B
ISOWE 50X12X63	●	50	12	63	165	42	AD/B
ISOWE 50X12X100	●	50	12	100	202	42	AD/B
ISOWE 50X12X160	●	50	12	160	262	42	AD/B
ISOWE 50X12X200	●	50	12	200	302	42	AD/B
ISOWE 50X14X63	●	50	14	63	165	42	AD/B
ISOWE 50X14X100	●	50	14	100	202	42	AD/B
ISOWE 50X16X63	●	50	16	63	165	48	AD/B
ISOWE 50X16X100	●	50	16	100	202	48	AD/B
ISOWE 50X16X160	●	50	16	160	262	48	AD/B
ISOWE 50X16X200	●	50	16	200	302	48	AD/B
ISOWE 50X18X63	●	50	18	63	165	48	AD/B
ISOWE 50X18X100	●	50	18	100	202	48	AD/B
ISOWE 50X18X160	●	50	18	160	262	48	AD/B
ISOWE 50X18X200	NEW ●	50	18	200	302	48	AD/B
ISOWE 50X20X35	NEW ●	50	20	35	137	70	AD/B
ISOWE 50X20X63	●	50	20	63	165	52	AD/B
ISOWE 50X20X100	●	50	20	100	202	52	AD/B
ISOWE 50X20X160	●	50	20	160	262	52	AD/B
ISOWE 50X20X200	●	50	20	200	302	52	AD/B
ISOWE 50X25X35	●	50	25	35	137	70	AD/B
ISOWE 50X25X80	●	50	25	80	182	63	AD/B
ISOWE 50X25X160	●	50	25	160	262	63	AD/B
ISOWE 50X25X200	●	50	25	200	302	63	AD/B
ISOWE 50X32X35	NEW ●	50	32	35	137	80	AD/B
ISOWE 50X32X100	●	50	32	100	202	70	AD/B
ISOWE 50X32X160	●	50	32	160	262	70	AD/B
ISOWE 50X32X200	●	50	32	200	302	70	AD/B
ISOWE 50X40X100	●	50	40	100	202	80	AD/B
ISOWE 50X50X120	●	50	50	120	212	90	AD/B

Accessori e Ricambi alla pagina successiva | Accessories and Spare Parts on the next page >>

## Accessori e Ricambi | Accessories &amp; Spare Parts

	Codice Code	Pagina Page
<b>01 MANDRINO A CAMBIO RAPIDO   QUICK CHANGE TAPPING CHUCK</b>		
Standard	WEMS	p. 284
<b>02 RIDUZIONI PER ATTACCO WELDON   REDUCTIONS FOR WELDON HOLDERS</b>		
Standard	RWE	p. 282
<b>03 PROLUNGHE WELDON PER PORTA PINZE ER   WELDON EXTENSIONS FOR ER COLLET CHUCKS</b>		
Standard	PGWE	p. 206
<b>04 VITE DI BLOCCAGGIO   CLAMPING SCREW</b>		
Standard	SWE ..	p. 280
<b>05 TIRANTI - DIN 69872   PULL STUDS - DIN 69872</b>		
Con foro di lubrificazione   With coolant bore	TRISOC	p. 262
Senza foro di lubrificazione   Without coolant bore	TRISOS	p. 263



01



02



03



04



05

## ISOWEG

### ATTACCO WELDON CON CANALINI DI LUBRIFICAZIONE WELDON HOLDERS WITH COOLANT GROOVES

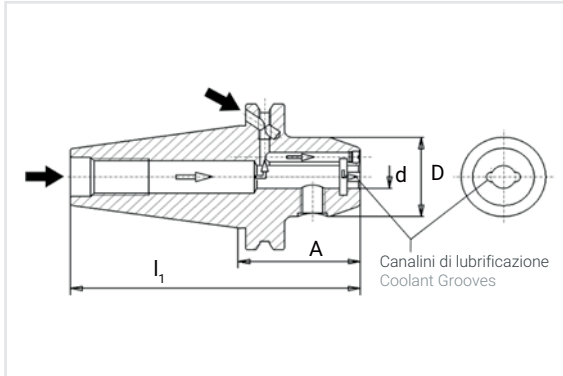

#### Dettagli tecnici | Technical details

Applicazione | Application

Forma | Form

Grado di bilanciatura | Degree of balancing

Run Out

Accessori forniti | Accessories provided

Elenco Accessori e Ricambi a richiesta  
List of Accessories & Spare parts on request

Per utensili con codolo cilindrico tipo weldon secondo norma DIN 1835B  
For tools with weldon type cylindrical shank according to DIN 1835B

AD/B

G 6.3 15.000 giri/min | G 6.3 15.000 rpm

Max. 15 µm (3 x d)

Vite di bloccaggio | Clamping screw

Vedi pagina 46 | See page 46

Codice d'ordine  
Order Code

STATUS

#### ISOWEG 40

ISOWEG 40X6X50	●
ISOWEG 40X6X100	●
ISOWEG 40X8X50	●
ISOWEG 40X8X100	●
ISOWEG 40X10X50	●
ISOWEG 40X10X100	●
ISOWEG 40X12X50	●

SK	d	A	l <sub>1</sub>	D
40	6	50	119	25
40	6	100	169	25
40	8	50	119	28
40	8	100	169	28
40	10	50	119	35
40	10	100	169	35
40	12	50	119	42

La gamma prosegue nella pagina successiva | The range continues on the next page >>

Codice d'ordine Order Code	STATUS	SK	d	A	I <sub>1</sub>	D
<b>ISOWEG 40</b>						
ISOWEG 40X12X100	●	40	12	100	169	42
ISOWEG 40X14X50	●	40	14	50	119	42
ISOWEG 40X16X63	●	40	16	63	132	48
ISOWEG 40X16X100	●	40	16	100	169	48
ISOWEG 40X18X63	●	40	18	63	132	48
ISOWEG 40X20X63	●	40	20	63	132	52
ISOWEG 40X20X100	●	40	20	100	169	52
ISOWEG 40X25X100	●	40	25	100	169	63
<b>ISOWEG 50</b>						
ISOWEG 50X6X63	●	50	6	63	165	25
ISOWEG 50X8X63	●	50	8	63	165	28
ISOWEG 50X10X63	●	50	10	63	165	35
ISOWEG 50X12X63	●	50	12	63	165	42
ISOWEG 50X14X63	●	50	14	63	165	42
ISOWEG 50X16X63	●	50	16	63	165	48
ISOWEG 50X18X63	●	50	18	63	165	48
ISOWEG 50X20X63	●	50	20	63	165	52
ISOWEG 50X25X80	●	50	25	80	182	63
ISOWEG 50X32X100	●	50	32	100	202	70
ISOWEG 50X40X100	●	50	40	100	202	90

## Accessori e Ricambi | Accessories & Spare Parts

	Codice Code	Pagina Page
<b>01 MANDRINO A CAMBIO RAPIDO   QUICK CHANGE TAPPING CHUCK</b>		
Standard	WEMS	p. 284
<b>02 RIDUZIONI PER ATTACCO WELDON   REDUCTIONS FOR WELDON HOLDERS</b>		
Standard	RWE	p. 282
<b>03 PROLUNGHE WELDON PER PORTA PINZE ER   WELDON EXTENSIONS FOR ER COLLET CHUCKS</b>		
Standard	PGWE	p. 206
<b>04 VITE DI BLOCCAGGIO   CLAMPING SCREW</b>		
Standard	SWE ..	p. 280
<b>05 TIRANTI - DIN 69872   PULL STUDS - DIN 69872</b>		
Con foro di lubrificazione   With coolant bore	TRISOC	p. 262
Senza foro di lubrificazione   Without coolant bore	TRISOS	p. 263

## ISOWNAD - ISOWN

### ATTACCO WHISTLE NOTCH WHISTLE-NOTCH HOLDERS

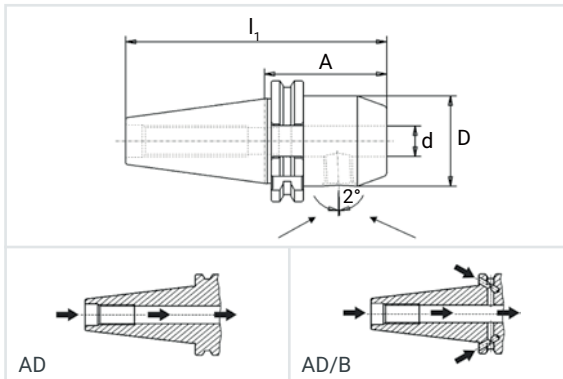

#### Dettagli tecnici | Technical details

Applicazione | Application

Forma | Form

Grado di bilanciatura | Degree of balancing

Run Out

Accessori forniti | Accessories provided

Elenco Accessori e Ricambi a richiesta  
List of Accessories & Spare parts on request

Per utensili con codolo cilindrico tipo whistle-notch secondo norma DIN 1835E | 6359HE.  
For tools with whistle-notch cylindrical shank according to DIN 1835E | 6359HE.

AD - AD/B

G 6.3 15.000 giri/min | G 6.3 15.000 rpm

Max. 15 µm (3 x d)

Vite di bloccaggio | Clamping screw

Vedi pagina 48 | See page 48

Codice d'ordine  
Order Code

STATUS

#### ISOWNAD 40

ISOWNAD 40X6X50	NEW ●
ISOWNAD 40X8X50	NEW ●
ISOWNAD 40X10X50	NEW ●
ISOWNAD 40X14X50	NEW ●
ISOWNAD 40X18X63	NEW ●

SK	d	A	l <sub>1</sub>	D	Forma Form
40	6	50	118	25	AD
40	8	50	118	28	AD
40	10	50	118	35	AD
40	14	50	118	42	AD
40	18	63	131	48	AD

La gamma prosegue nella pagina successiva | The range continues on the next page >>

Codice d'ordine Order Code	STATUS	SK	d	A	l <sub>1</sub>	D	Forma Form
<b>ISOWN 40</b>							
ISOWN 40X6X50	●	40	6	50	118	25	AD/B
ISOWN 40X8X50	●	40	8	50	118	28	AD/B
ISOWN 40X10X50	●	40	10	50	118	35	AD/B
ISOWN 40X12X50	●	40	12	50	118	42	AD/B
ISOWN 40X14X50	●	40	14	50	118	42	AD/B
ISOWN 40X16X63	●	40	16	63	131	48	AD/B
ISOWN 40X18X63	●	40	18	63	131	48	AD/B
ISOWN 40X20X63	●	40	20	63	131	52	AD/B
ISOWN 40X25X100	●	40	25	100	168	63	AD/B
ISOWN 40X32X100	●	40	32	100	168	70	AD/B
ISOWN 40X40X120	NEW ●	40	40	120	188	80	AD/B
<b>ISOWN 50</b>							
ISOWN 50X6X63	●	50	6	63	165	25	AD/B
ISOWN 50X8X63	●	50	8	63	165	28	AD/B
ISOWN 50X10X63	●	50	10	63	165	35	AD/B
ISOWN 50X12X63	●	50	12	63	165	42	AD/B
ISOWN 50X14X63	●	50	14	63	165	42	AD/B
ISOWN 50X16X63	●	50	16	63	165	48	AD/B
ISOWN 50X18X63	●	50	18	63	165	48	AD/B
ISOWN 50X20X63	●	50	20	63	165	52	AD/B
ISOWN 50X25X80	●	50	25	80	182	63	AD/B
ISOWN 50X32X100	●	50	32	100	202	70	AD/B
ISOWN 50X40X100	●	50	40	100	202	80	AD/B

## Accessori e Ricambi | Accessories & Spare Parts

	Codice Code	Pagina Page
<b>01 VITE DI BLOCCAGGIO   CLAMPING SCREW</b>		
Standard	SWE ..	p. 280
<b>02 TIRANTI - DIN 69872   PULL STUDS - DIN 69872</b>		
Con foro di lubrificazione   With coolant bore	TRISOC	p. 262
Senza foro di lubrificazione   Without coolant bore	TRISOS	p. 263



01



02



## ISOFI-ISOFIB

### PORTAFRESE FISSI (DIN 6357) SHELL END MILL HOLDERS (DIN 6357)

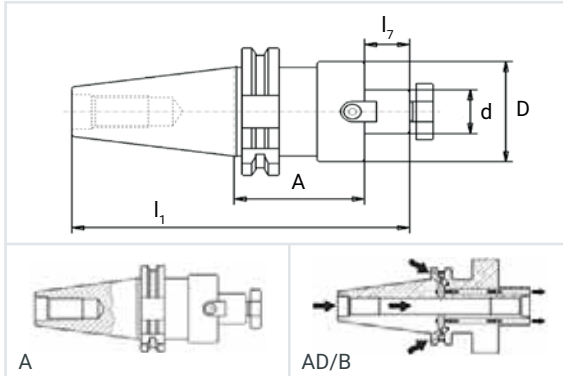

#### Dettagli tecnici | Technical details

Applicazione   Application	Per frese con scanalatura trasversale For end mills with cross groove
Forma   Form	A - AD/B
Grado di bilanciatura   Degree of balancing	-
Run Out	Max. 8 µm
Accessori forniti   Accessories provided	Con due chiavette di trascinamento fisse e vite di bloccaggio DIN 6367 With two fixed drive keys and clamping screw DIN 6367
Elenco Accessori e Ricambi a richiesta List of Accessories & Spare parts on request	Vedi pagina 51   See page 51

Codice d'ordine Order Code	STATUS	SK	d	A	l <sub>1</sub>	l <sub>2</sub>	D	Forma Form
<b>ISOFI 30</b>								
ISOFI 30X16X40	NEW ●	30	16	40	105	17	38	A
ISOFI 30X22X40	NEW ●	30	22	40	107	19	48	A
ISOFI 30X27X50	NEW ●	30	27	50	119	21	58	A
<b>ISOFI 40</b>								
ISOFI 40X16X35	●	40	16	35	120	17	38	A
ISOFI 40X16X100	●	40	16	100	185	17	38	A

La gamma prosegue nella pagina successiva | The range continues on the next page >>

Codice d'ordine Order Code	STATUS	SK	d	A	l <sub>1</sub>	l <sub>2</sub>	D	Forma Form
<b>ISOFI 40</b>								
ISOFI 40X22X35	●	40	22	35	122	19	44,45	A
ISOFI 40X22X50	●	40	22	50	137	19	48	A
ISOFI 40X22X100	●	40	22	100	187	19	48	A
ISOFI 40X27X35	●	40	27	35	124	21	44,45	A
ISOFI 40X27X50	●	40	27	50	139	21	58	A
ISOFI 40X27X100	●	40	27	100	189	21	58	A
ISOFI 40X32X55	●	40	32	55	148	24	78	A
ISOFI 40X32X100	●	40	32	100	193	24	78	A
ISOFI 40X40X60	●	40	40	60	156	27	88,88	A
<b>ISOFI 50</b>								
ISOFI 50X22X35	●	50	22	35	156	19	48	A
ISOFI 50X22X100	●	50	22	100	221	19	48	A
ISOFI 50X27X35	●	50	27	35	158	21	58	A
ISOFI 50X27X100	●	50	27	100	223	21	58	A
ISOFI 50X27X160	NEW ●	50	27	160	283	21	58	A
ISOFI 50X32X35	●	50	32	35	161	24	78	A
ISOFI 50X32X100	●	50	32	100	244	24	78	A
ISOFI 50X40X55	●	50	40	55	184	27	89	A
ISOFI 50X60X70	■	50	60	70	202	40	129	A
<b>ISOFIB 40</b>								
ISOFIB 40X16X35	NEW ●	40	16	35	120	17	38	AD/B
ISOFIB 40X16X100	NEW ●	40	16	100	185	17	38	AD/B
ISOFIB 40X22X35	●	40	22	35	122	19	44,45	AD/B
ISOFIB 40X22X50	●	40	22	50	137	19	48	AD/B
ISOFIB 40X22X100	●	40	22	100	187	19	48	AD/B
ISOFIB 40X22X160	NEW ●	40	22	160	247	19	48	AD/B
ISOFIB 40X27X35	●	40	27	35	124	21	44,45	AD/B
ISOFIB 40X27X50	●	40	27	50	139	21	58	AD/B
ISOFIB 40X27X100	NEW ●	40	27	100	189	21	58	AD/B
ISOFIB 40X32X55	●	40	32	55	148	24	78	AD/B
ISOFIB 40X32X100	NEW ●	40	32	100	193	24	78	AD/B
ISOFIB 40X40X60	●	40	40	60	156	27	88,88	AD/B
<b>ISOFIB 50</b>								
ISOFIB 50X16X45	NEW ●	50	16	45	164	17	38	AD/B
ISOFIB 50X16X100	NEW ●	50	16	100	219	17	38	AD/B
ISOFIB 50X16X160	NEW ●	50	16	160	279	17	38	AD/B
ISOFIB 50X22X35	●	50	22	35	156	19	48	AD/B
ISOFIB 50X22X100	NEW ●	50	22	100	221	19	48	AD/B
ISOFIB 50X22X160	NEW ●	50	22	160	281	19	48	AD/B

■ Fino ad esaurimento scorte | Till stocks last La gamma prosegue nella pagina successiva | The range continues on the next page >>

Codice d'ordine Order Code	STATUS	SK	d	A	l <sub>1</sub>	l <sub>2</sub>	D	Forma Form
<b>ISOFIB 50</b>								
ISOFIB 50X27X35	●	50	27	35	158	21	58	AD/B
ISOFIB 50X27X100	NEW ●	50	27	100	223	21	58	AD/B
ISOFIB 50X27X160	NEW ●	50	27	160	283	21	58	AD/B
ISOFIB 50X32X35	●	50	32	35	161	24	78	AD/B
ISOFIB 50X32X100	●	50	32	100	244	24	78	AD/B
ISOFIB 50X32X160	NEW ●	50	32	160	304	24	78	AD/B
ISOFIB 50X40X55	●	50	40	55	184	27	88,88	AD/B
ISOFIB 50X60X70	NEW ●	50	60	70	202	40	129	AD/B

## Accessori e Ricambi | Accessories & Spare Parts

	Codice Code	Pagina Page
<b>01 CHIAVE DI BLOCCAGGIO   CLAMPING WRENCH</b>		
Standard	CVCR	p. 279
<b>02 VITE DI BLOCCAGGIO   CLAMPING SCREW</b>		
Standard	VTGR	p. 281
<b>03 TIRANTI - DIN 69872   PULL STUDS - DIN 69872</b>		
Con foro di lubrificazione   With coolant bore	TRISOC	p. 262
Senza foro di lubrificazione   Without coolant bore	TRISOS	p. 263
<b>04 PROLUNGHE PER PORTA FRESE   EXTENSIONS FOR SHELL END MILLS HOLDERS</b>		
Standard	PRFI	p. 212



01



02



03



04

## ISOAC-ISOACB

### PORTAFRESE COMBINATI (DIN 6358) COMBI SHELL END MILL HOLDERS (DIN 6358)

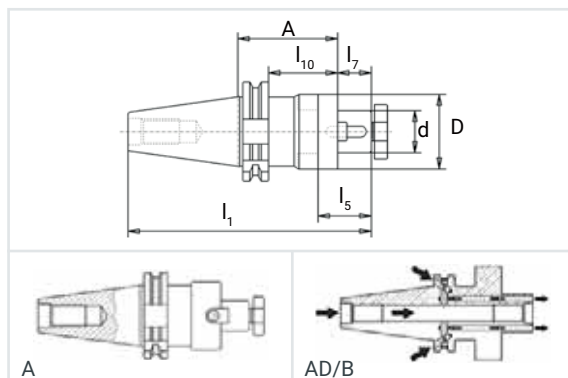

#### Dettagli tecnici | Technical details

Applicazione | Application

Per frese con scanalatura longitudinale o trasversale  
For end mills with longitudinal and cross groove

Forma | Form

A - AD/B

Grado di bilanciatura | Degree of balancing

-

Run Out

Max. 8  $\mu$ m

Accessori forniti | Accessories provided

Con Vite di bloccaggio DIN 6367, anello di trascinamento DIN 6366 e chiave di bloccaggio.  
With clamping screw DIN 6367, drive ring DIN 6366 and feather key.

Elenco Accessori e Ricambi a richiesta  
List of Accessories & Spare parts on request

Vedi pagina 54 | See page 54

Codice d'ordine  
Order Code

STATUS

#### ISOAC 30

ISOAC 30X16X50	NEW ●
ISOAC 30X22X50	NEW ●
ISOAC 30X27X55	NEW ●
ISOAC 30X32X60	NEW ●

#### ISOAC 40

ISOAC 40X16X55	●
----------------	---

SK	d	A	I <sub>1</sub>	I <sub>5</sub>	I <sub>7</sub>	I <sub>10</sub>	D	Forma Form
30	16	50	115	27	17	31	32	A
30	22	50	117	31	19	31	40	A
30	27	55	119	33	21	31	48	A
30	32	60	122	38	24	41	58	A
40	16	55	141	27	17	36	32	A

La gamma prosegue nella pagina successiva | The range continues on the next page >>

Codice d'ordine Order Code	STATUS	SK	d	A	l <sub>1</sub>	l <sub>5</sub>	l <sub>7</sub>	l <sub>10</sub>	D	Forma Form
<b>ISOAC 40</b>										
ISOAC 40X16X100	●	40	16	100	186	27	17	81	32	A
ISOAC 40X22X55	●	40	22	55	143	31	19	36	40	A
ISOAC 40X22X100	●	40	22	100	188	31	19	81	40	A
ISOAC 40X22X160	■	40	22	160	248	31	19	141	40	A
ISOAC 40X27X62	●	40	27	62	152	33	21	43	48	A
ISOAC 40X27X100	●	40	27	100	190	33	21	81	48	A
ISOAC 40X27X160	●	40	27	160	250	33	21	141	48	A
ISOAC 40X32X60	●	40	32	60	152	38	24	41	58	A
ISOAC 40X32X100	●	40	32	100	193	38	24	81	58	A
ISOAC 40X40X60	NEW ●	40	40	60	156	41	27	41	70	A
ISOAC 40X40X100	NEW ●	40	40	100	196	41	27	81	70	A
ISOAC 40X40X160	NEW ●	40	40	160	256	41	27	141	70	A
<b>ISOAC 50</b>										
ISOAC 50X16X55	●	50	16	55	174	27	17	36	32	A
ISOAC 50X16X100	●	50	16	100	219	27	17	81	32	A
ISOAC 50X16X160	●	50	16	160	279	27	17	141	32	A
ISOAC 50X22X55	●	50	22	55	176	31	19	36	40	A
ISOAC 50X22X100	●	50	22	100	221	31	19	81	40	A
ISOAC 50X22X160	●	50	22	160	281	31	19	141	40	A
ISOAC 50X27X55	●	50	27	55	178	33	21	36	48	A
ISOAC 50X27X100	●	50	27	100	223	33	21	81	48	A
ISOAC 50X27X160	●	50	27	160	283	33	21	141	48	A
ISOAC 50X32X55	●	50	32	55	181	38	24	36	58	A
ISOAC 50X32X100	●	50	32	100	226	38	24	81	58	A
ISOAC 50X32X160	●	50	32	160	286	38	24	141	58	A
ISOAC 50X40X55	●	50	40	55	184	41	27	36	70	A
ISOAC 50X40X100	●	50	40	100	229	41	27	81	70	A
ISOAC 50X50X70	●	50	50	70	207	46	30	56	90	A
<b>ISOACB 40</b>										
ISOACB 40X16X55	NEW ●	40	16	55	141	27	17	36	32	AD/B
ISOACB 40X16X100	NEW ●	40	16	100	186	27	17	81	32	AD/B
ISOACB 40X16X160	NEW ●	40	16	160	246	27	17	141	32	AD/B
ISOACB 40X22X55	NEW ●	40	22	55	143	31	19	36	40	AD/B
ISOACB 40X22X100	NEW ●	40	22	100	188	31	19	81	40	AD/B
ISOACB 40X22X160	NEW ●	40	22	160	248	31	19	141	40	AD/B
ISOACB 40X27X62	NEW ●	40	27	62	152	33	21	43	48	AD/B
ISOACB 40X27X100	NEW ●	40	27	100	190	33	21	81	48	AD/B
ISOACB 40X27X160	NEW ●	40	27	160	250	33	21	141	48	AD/B
ISOACB 40X32X60	NEW ●	40	32	60	152	38	24	41	58	AD/B
ISOACB 40X32X100	NEW ●	40	32	100	193	38	24	81	58	AD/B

■ Fino ad esaurimento scorte | Till stocks last    La gamma prosegue nella pagina successiva | The range continues on the next page >>

Codice d'ordine Order Code	STATUS	SK	d	A	l <sub>1</sub>	l <sub>5</sub>	l <sub>7</sub>	l <sub>10</sub>	D	Forma Form
<b>ISOACB 40</b>										
ISOACB 40X32X160	NEW ●	40	32	160	253	38	24	141	58	AD/B
ISOACB 40X40X60	NEW ●	40	40	60	156	41	27	41	70	AD/B
<b>ISOACB 50</b>										
ISOACB 50X16X55	NEW ●	50	16	55	174	27	17	36	32	AD/B
ISOACB 50X16X100	NEW ●	50	16	100	219	27	17	81	32	AD/B
ISOACB 50X22X55	NEW ●	50	22	55	176	31	19	36	40	AD/B
ISOACB 50X22X100	NEW ●	50	22	100	221	31	19	81	40	AD/B
ISOACB 50X27X55	NEW ●	50	27	55	178	33	21	36	48	AD/B
ISOACB 50X27X100	NEW ●	50	27	100	223	33	21	81	48	AD/B
ISOACB 50X32X55	NEW ●	50	32	55	181	38	24	36	58	AD/B
ISOACB 50X32X100	NEW ●	50	32	100	226	38	24	81	58	AD/B
ISOACB 50X40X55	NEW ●	50	40	55	184	41	27	36	70	AD/B

## Accessori e Ricambi | Accessories & Spare Parts

	Codice Code	Pagina Page
<b>01 CHIAVE DI BLOCCAGGIO   CLAMPING WRENCH</b>		
Standard	CVCR	p. 279
<b>02 VITE DI BLOCCAGGIO   CLAMPING SCREW</b>		
Standard	VTGR	p. 281
<b>03 ANELLO DI TRASCINAMENTO   DRIVE RING</b>		
Standard	ANTR	p. 286
<b>04 TIRANTI - DIN 69872   PULL STUDS - DIN 69872</b>		
Con foro di lubrificazione   With coolant bore	TRISOC	p. 262
Senza foro di lubrificazione   Without coolant bore	TRISOS	p. 263



01



02



03



04

## ISOIX

### PORTAPUNTE A FISSAGGIO MECCANICO INDEXABLE DRILL HOLDERS

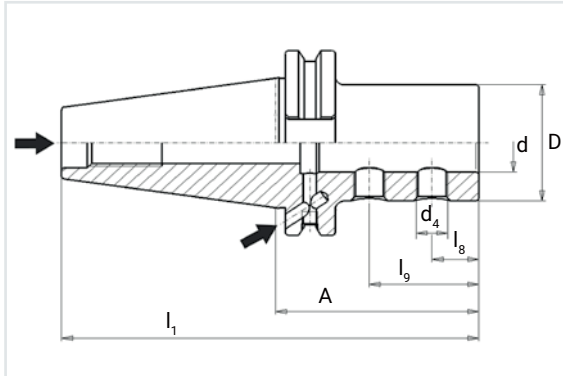

#### Dettagli tecnici | Technical details

Applicazione | Application

Per corpo punta a fissaggio meccanico con codolo cilindrico secondo norma DIN 9766.  
For index drill with cylindrical shank according to DIN 9766 standard.

Forma | Form

AD/B

Grado di bilanciatura | Degree of balancing

G 6.3 15.000 giri/min | G 6.3 15.000 rpm

Accessori e Ricambi a richiesta  
Accessories & Spare parts on request

Tiranti (vedi pagina 260-261) | Pull Studs (see page 260-261)

Codice d'ordine  
Order Code

STATUS

SK d A l<sub>1</sub> l<sub>8</sub> l<sub>9</sub> D d<sub>4</sub>

#### ISOIX 40

ISOIX 40X20	●
ISOIX 40X25	●
ISOIX 40X32	●
ISOIX 40X40	●

40	20	65	133	15	35	40	M10x1
40	25	70	138	17	40	45	M12x1
40	32	75	143	17	44	52	M12x1
40	40	115	183	22	50	60	M16x1

#### ISOIX 50

ISOIX 50X20	●
ISOIX 50X25	●
ISOIX 50X32	●
ISOIX 50X40	●

50	20	70	172	15	35	40	M10x1
50	25	70	172	17	40	45	M12x1
50	32	70	172	17	44	52	M12x1
50	40	80	182	22	50	60	M16x1

## ISOAS

### PORTAPUNTE AUTOSERRANTI (STANDARD) DRILL CHUCKS (STANDARD)

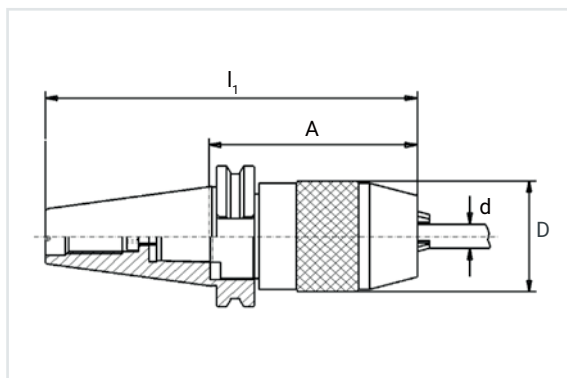

#### Dettagli tecnici | Technical details

Applicazione | Application

Per punte con codolo cilindrico in differenti tolleranze  
For drills with cylindrical shank in different tolerances

Forma | Form

A

Grado di bilanciatura | Degree of balancing

-

Run Out

Max. 50 µm

Accessori forniti | Accessories provided

Chiave | Key

Accessori e Ricambi a richiesta

Accessories & Spare parts on request

Tiranti (vedi pagina 260-261) | Pull Studs (see page 260-261)

Codice d'ordine  
Order Code

STATUS

SK

d

A

l<sub>1</sub>

D

#### ISOAS 40

ISOAS 40X13 ●

40 13 87 156 51

ISOAS 40X16 ●

40 16 110 179 57

#### ISOAS 50

ISOAS 50X13 ●

50 13 86 188 51

ISOAS 50X16 ●

50 16 90 192 57



## ISODS-ISODSB

### PORTAPUNTE AUTOSERRANTI (ALTA PRECISIONE) DRILL CHUCKS (HIGH PRECISION)

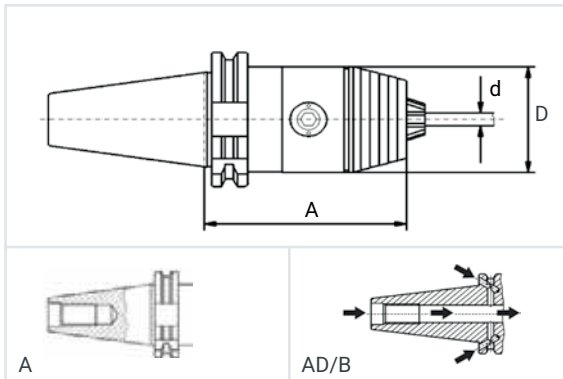

#### Dettagli tecnici | Technical details

Applicazione | Application

Per punte con codolo cilindrico in differenti tolleranze  
For drills with cylindrical shank in different tolerances

Forma | Form

A - AD/B

Grado di bilanciatura | Degree of balancing

-

Run Out

Max. 20  $\mu\text{m}$  (3 x d)

Accessori forniti | Accessories provided

Chiave | Key

Elenco Accessori e Ricambi a richiesta  
List of Accessories & Spare parts on request

Vedi pagina 58 | See page 58

Codice d'ordine  
Order Code

STATUS

SK

d

A

D

Range

Forma  
Form

#### ISODS 30

ISODS 30X8	●
ISODS 30X13	●

30	8	70	36	0,3-8	A
30	13	111	50	0,5-13	A

#### ISODS 40

ISODS 40X8	●
ISODS 40X13	●
ISODS 40X16	●

40	8	76	36	0,3-8	A
40	13	90	50	0,5-13	A
40	16	95	57	2,5-16	A

La gamma prosegue nella pagina successiva | The range continues on the next page >>

Codice d'ordine Order Code	STATUS	SK	d	A	D	Range	Forma Form
<b>ISODS 50</b>							
ISODS 50X13	●	50	13	106	50	0,5-13	A
ISODS 50X16	●	50	16	111	57	2,5-16	A
<b>ISODSB 40</b>							
ISODSB 40X8	●	40	8	76	36	0,3-8	AD/B
ISODSB 40X13	●	40	13	95	50	0,5-13	AD/B
ISODSB 40X16	●	40	16	100	57	2,5-16	AD/B
<b>ISODSB 50</b>							
ISODSB 50X13	●	50	13	106	50	0,5-13	AD/B
ISODSB 50X16	●	50	16	111	57	2,5-16	AD/B

### Accessori e Ricambi | Accessories & Spare Parts

	Codice Code	Pagina Page
<b>04 TIRANTI - DIN 69872   PULL STUDS - DIN 69872</b>		
Con foro di lubrificazione   With coolant bore	TRISOC	p. 262
Senza foro di lubrificazione   Without coolant bore	TRISOS	p. 263



01

## ISOMS

### PORTA MASCHI TAPPING CHUCKS

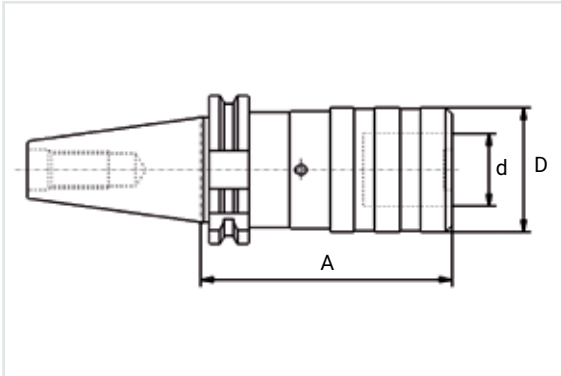

#### Dettagli tecnici | Technical details

Applicazione | Application

Per bussole porta maschio a cambio rapido con compensazione assiale  
For quick change tapping chuck with axial compensation

Forma | Form

A

Grado di bilanciatura | Degree of balancing

-

Run Out

-

Accessori forniti | Accessories provided

-

Elenco Accessori e Ricambi a richiesta  
List of Accessories & Spare parts on request

Vedi pagina 60 | See page 60

Codice d'ordine  
Order Code

STATUS

SK	Tipo Type	d	A	D	M
----	--------------	---	---	---	---

#### ISOMS 30

ISOMS 30X1	●
ISOMS 30X2	●

30	1	19	60	38	M3-M12
30	2	31	101	55	M8-M20

#### ISOMS 40

ISOMS 40X1	●
ISOMS 40X2	●
ISOMS 40X3	●

40	1	19	60	38	M3-M12
40	2	31	100	55	M8-M20
40	3	48	138	78	M14-M33

La gamma prosegue nella pagina successiva | The range continues on the next page >>

Codice d'ordine Order Code	STATUS	SK	Tipo Type	d	A	D	M
<b>ISOMS 50</b>							
ISOMS 50X1	●	50	1	19	62	38	M3-M12
ISOMS 50X2	●	50	2	31	83	55	M8-M20
ISOMS 50X3	●	50	3	48	133	78	M14-M33

### Accessori e Ricambi | Accessories & Spare Parts

	Codice Code	Pagina Page
<b>01 PINZE CON FRIZIONE   TAPPING COLLETS WITH CLUTCH</b>		
Standard	PZCFR	p. 242
<b>02 PINZE SENZA FRIZIONE   TAPPING COLLETS WITHOUT CLUTCH</b>		
Standard	PZSFR	p. 244



01



02

## Dimensione codolo maschio | Dimensions of tap-shafts

Dimensione Size	DIN 352	DIN 353	DIN 371	DIN 374	DIN 376	DIN 2182	DIN 2183
<b>2,5 x 2,1</b>	M 1		M 1		M 3,5	1/16"	
	M 1,1		M 1,1	M 3,5			
	M 1,2		M 1,2				
	M 1,4		M 1,4				
	M 1,6		M 1,6				
	M 1,8		M 1,8				
<b>2,8 x 2,1</b>	M 2		M 2	M 4	M 4	3/32"	5/32"
	M 2,2		M 2,2				
	M 2,5		M 2,5				
<b>3,5 x 2,7</b>	M 3		M 3	M 5	M 5	1/8"	
<b>4 x 3</b>	M 3,5		M 3,5			7/32"	
<b>4,5 x 3,4</b>	M 4		M 4	M 6	M 6	5/32"	1/4"
<b>6 x 4,9</b>	M 5		M 5				
	M 6		M 6				
	M 8			M 8	M 8		
<b>7 x 5,5</b>	M 10	G 1/8"		M 10	M 10	1/4"	3/8"
<b>8 x 6,2</b>			M 8			5/16"	7/16"
<b>9 x 7</b>	M 12			M 12	M 12	3/8"	1/2"
<b>10 x 8</b>			M 10				
<b>11 x 9</b>	M 14	G 1/4"		M 14	M 14		9/16"
<b>12 x 9</b>	M 16	G 3/8"		M 16	M 16		5/8"
<b>14 x 11</b>	M 18			M 18	M 18		11/16"
<b>16 x 12</b>	M 20	G 1/2"		M 20	M 20		13/16"
<b>18 x 14,5</b>	M 22	G 5/8"		M 22	M 22		7/8"
	M 24			M 24	M 24		15/16"
<b>20 x 16</b>	M 27	G 3/4"		M 27	M 27		1"
<b>22 x 18</b>	M 30	G 7/8"		M 30	M 30		1.1/8"
<b>25 x 20</b>	M 33	G 1"		M 33	M 33		1.1/4"
<b>28 x 22</b>	M 36	G 1.1/8"		M 36	M 36		1.3/8"
<b>32 x 24</b>	M 39	G 1.1/4"		M 39	M 39		1.1/2"
	M 42			M 42	M 42		1.5/8"
<b>36 x 29</b>	M 45	G 1.3/8"		M 45	M 45		1.3/4"
	M 48	G 1.1/2"		M 48	M 48		1.7/8"
		G 1.3/4"					
		G 2"					
<b>40 x 32</b>	M 52	G 2.1/4"		M 52	M 52		2"
<b>45 x 35</b>	M 56	G 2.1/2"			M 56		2.1/4"
	M 60				M 60		2.1/2"
<b>50 x 39</b>	M 64	G 2.3/4"			M 64		2.1/2"
		G 3"					
<b>56 x 44</b>	M 68	G 3.1/4"			M 68		2.3/4"

## ISOCM-ISOCMB

### ATTACCO CONO MORSE PER PUNTE (DIN 6383)

### MORSE TAPER FOR DRILLS (DIN 6383)

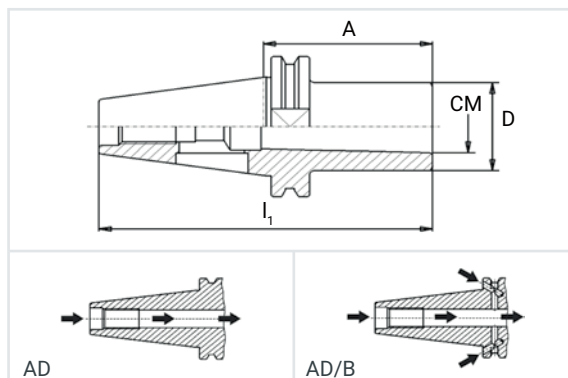

#### Dettagli tecnici | Technical details

Applicazione | Application

Per punte attacco cono morse  
For drills with cono morse shank

Forma | Form

A - AD - AD/B

Grado di bilanciatura | Degree of balancing

G 6.3 15.000 giri/min | G 6.3 15.000 rpm

Run Out

Max. 10 µm

Accessori forniti | Accessories provided

-

Elenco Accessori e Ricambi a richiesta  
List of Accessories & Spare parts on request

Vedi pagina 63 | See page 63

Codice d'ordine  
Order Code

STATUS

SK

CM

A

l<sub>1</sub>

D

Forma  
Form

#### ISOCM 30

ISOCM 30X1X50	●
ISOCM 30X2X65	●
ISOCM 30X3X80	●

30	1	50	103	25	AD
30	2	65	113	32	AD
30	3	80	128	40	AD

#### ISOCM 40

ISOCM 40X1X50	●
ISOCM 40X2X50	●

40	1	50	119	25	AD
40	2	50	119	32	AD

La gamma prosegue nella pagina successiva | The range continues on the next page >>

Codice d'ordine Order Code	STATUS	SK	CM	A	I <sub>1</sub>	D	Forma Form
<b>ISOCM 40</b>							
ISOCM 40X2X117	●	40	2	117	186	32	AD
ISOCM 40X2X150	●	40	2	150	219	32	AD
ISOCM 40X3X70	●	40	3	70	139	40	AD
ISOCM 40X3X133	●	40	3	133	202	40	AD
ISOCM 40X4X95	●	40	4	95	164	48	AD
ISOCM 40X4X156	●	40	4	156	226	48	AD
<b>ISOCM 50</b>							
ISOCM 50X1X45	●	50	1	45	147	25	AD
ISOCM 50X1X120	NEW ●	50	1	120	222	25	A
ISOCM 50X2X50	●	50	2	50	152	32	AD
ISOCM 50X2X117	●	50	2	117	219	32	AD
ISOCM 50X2X150	●	50	2	150	252	32	AD
ISOCM 50X3X65	●	50	3	65	167	40	AD
ISOCM 50X3X137	●	50	3	137	239	40	AD
ISOCM 50X3X150	●	50	3	150	252	33	AD
ISOCM 50X4X95	●	50	4	95	197	48	AD
ISOCM 50X4X167	●	50	4	167	269	48	AD
ISOCM 50X5X105	●	50	5	105	207	63	AD
ISOCM 50X5X200	NEW ●	50	5	200	302	63	A
<b>ISOCMB 40</b>							
ISOCMB 40X1X50	NEW ●	40	1	50	119	25	AD/B
ISOCMB 40X2X50	NEW ●	40	2	50	119	32	AD/B
ISOCMB 40X3X70	NEW ●	40	3	70	139	40	AD/B
ISOCMB 40X4X95	NEW ●	40	4	95	164	48	AD/B
<b>ISOCMB 50</b>							
ISOCMB 50X1X45	NEW ●	50	1	45	147	25	AD/B
ISOCMB 50X2X50	NEW ●	50	2	50	152	32	AD/B
ISOCMB 50X3X65	NEW ●	50	3	65	167	40	AD/B
ISOCMB 50X4X95	NEW ●	50	4	95	197	48	AD/B

## Accessori e Ricambi | Accessories & Spare Parts

	Codice Code	Pagina Page
<b>01 TIRANTI - DIN 69872   PULL STUDS - DIN 69872</b>		
DIN 69872 - Con foro e senza foro di lubrificazione   DIN 69872 - With and Without coolant bore	TRISO.	p. 262-263
ISO 7388 B - Con foro e senza foro di lubrificazione   ISO 7388 B - With and Without coolant bore	7388B.	p. 265
<b>02 TENONE DI ESPULSIONE   TANGS TO SCREW IN</b>		
Standard	TEVT	p. 273

## ISOMK

### ATTACCO CONO MORSE PER FRESE (DIN 6364)

### MORSE TAPER FOR END MILLS (DIN 6364)

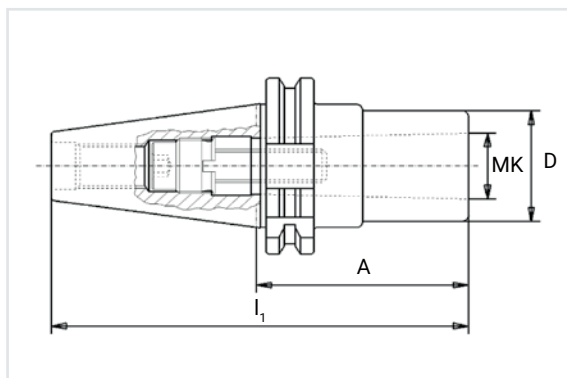

#### Dettagli tecnici | Technical details

Applicazione | Application

Per frese attacco cono morse  
For end mills with cono morse shank

Forma | Form

A

Grado di bilanciatura | Degree of balancing

-

Run Out

Max. 10 µm

Accessori forniti | Accessories provided

Vite di bloccaggio | Clamping screw

Elenco Accessori e Ricambi a richiesta  
List of Accessories & Spare parts on request

Vedi pagina 65 | See page 65

Codice d'ordine  
Order Code

STATUS

SK

MK

A

I<sub>1</sub>

D

#### ISOMK 30

ISOMK 30X1X50 ●

30 1 50 98 25

ISOMK 30X3X82 ●

30 3 82 130 40

#### ISOMK 40

ISOMK 40X1X50 ●

40 1 50 119 25

ISOMK 40X1X100 ●

40 1 100 169 25

ISOMK 40X2X50 ●

40 2 50 119 32

La gamma prosegue nella pagina successiva | The range continues on the next page >>



Codice d'ordine Order Code	STATUS	SK	MK	A	I <sub>1</sub>	D
<b>ISOMK 40</b>						
ISOMK 40X2X100	●	40	2	100	169	32
ISOMK 40X3X70	●	40	3	70	139	40
ISOMK 40X3X100	●	40	3	100	169	40
ISOMK 40X4X95	●	40	4	95	164	48
ISOMK 40X4X150	●	40	4	150	219	48
ISOMK 40X4X200	●	40	4	200	269	48
<b>ISOMK 50</b>						
ISOMK 50X1X45	●	50	1	45	147	25
ISOMK 50X2X60	●	50	2	60	162	32
ISOMK 50X3X65	●	50	3	65	167	40
ISOMK 50X4X95	●	50	4	95	197	48
ISOMK 50X4X150	●	50	4	150	252	48
ISOMK 50X4X200	●	50	4	200	302	48
ISOMK 50X5X105	●	50	5	105	207	63
ISOMK 50X5X150	●	50	5	150	252	63
ISOMK 50X5X200	●	50	5	200	302	63

## Accessori e Ricambi | Accessories & Spare Parts

	Codice Code	Pagina Page
<b>01 TIRANTI - DIN 69872   PULL STUDS - DIN 69872</b>		
Con foro di lubrificazione   With bore	TRISOC	p. 262
Senza foro di lubrificazione   Without bore	TRISOS	p. 263
<b>02 TIRANTI PROLUNGATI - DIN 69872   EXTENDED PULL STUDS - DIN 69872</b>		
Senza foro di lubrificazione   Without bore	TRXLS	p. 264



01



02

## ISOD

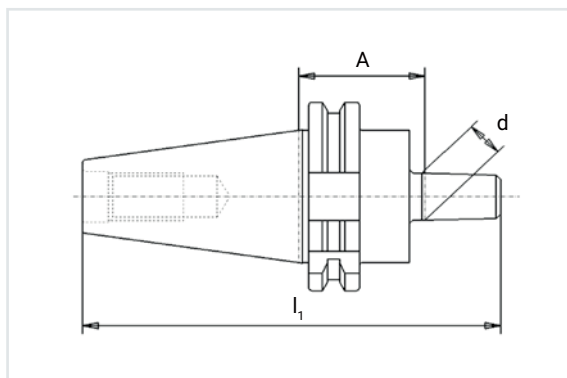
ATTACCO CONICO (DIN 238)  
TAPER SHAFTS (DIN 238)

## Dettagli tecnici | Technical details

Applicazione | Application

Per mandrini DIN 238  
For toolholders DIN 238

Forma | Form

A

Accessori forniti | Accessories provided

-

Elenco Accessori e Ricambi a richiesta  
List of Accessories & Spare parts on request

Tiranti (vedi pagina 260-261) | Pull Studs (see page 260-261)

Codice d'ordine  
Order Code

STATUS

SK

d

A

l<sub>1</sub>

## ISOD 30

ISOD 30X16

●

30

16

25

112

## ISOD 40

ISOD 40X12

●

40

12

25

112

ISOD 40X16

●

40

16

25

117

ISOD 40X18

●

40

18

35

135

## ISOD 50

ISOD 50X16

●

50

16

25

151

ISOD 50X18

●

50

18

25

159

## ISOMR

### MANDRINI DI RIDUZIONE REDUCTION ARBOR

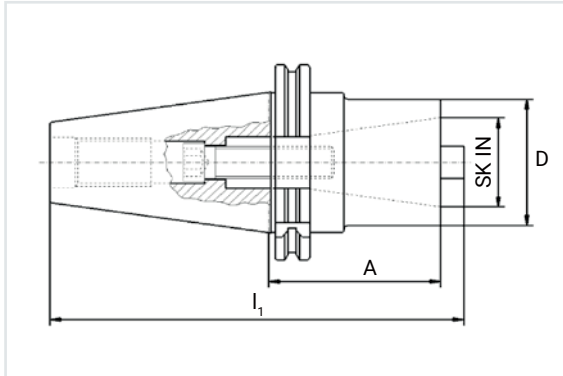

#### Dettagli tecnici | Technical details

Applicazione   Application	Per riduzione cono ad elevata rastrematura SK For SK high taper cone reduction
Forma   Form	A
Accessori forniti   Accessories provided	Vite di bloccaggio   Clamping screw
Accessori e Ricambi a richiesta Accessories & Spare parts on request	Tiranti (vedi pagina 260-261)   Pull Studs (see page 260-261)

Codice d'ordine Order Code	STATUS	SK Out/In	A	l <sub>1</sub>	D
<b>ISOMR 40</b>					
ISOMR 40X30	NEW ●	40 X 30	50	119	50
ISOMR 40X40	NEW ●	40 X 40	100	169	70
<b>ISOMR 50</b>					
ISOMR 50X40	NEW ●	50 X 40	70	172	70
ISOMR 50X50	NEW ●	50 X 50	120	222	97

In fase d'ordine specificare se si desidera ridurre o prolungare un cono DIN2080, DIN69871 o MAS BT.  
When ordering please give information whether you want to reduce or extend a taper DIN2080, DIN69871 or MAS BT.

## ISOSL

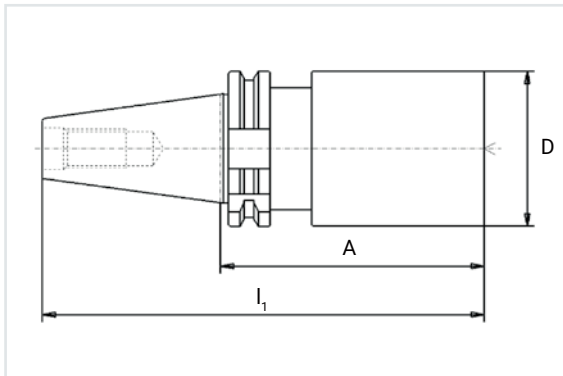
SEMI LAVORATO  
BLANK BARS

## Dettagli tecnici | Technical details

Applicazione | Application

Per la produzione di mandrini speciali  
For the production of special tool holders

Forma | Form

A

Accessori e Ricambi a richiesta  
Accessories & Spare parts on request

Tiranti (vedi pagina 260-261) | Pull Studs (see page 260-261)

Codice d'ordine  
Order Code

STATUS

SK

A

 $I_1$ 

D

## ISOSL 40

ISOSL 40X63X160 NEW ●

40 160 229 63

ISOSL 40X63X250 NEW ●

40 250 319 63

## ISOSL 50

ISOSL 50X97X315 NEW ●

50 315 417 97

## ISOCK

### BARRE DI CONTROLLO TEST ARBORS

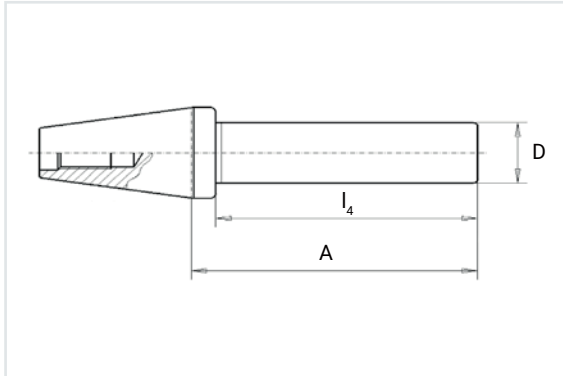

#### Dettagli tecnici | Technical details

Applicazione   Application	Per controllo accurato della rotazione del mandrino For testing of accuracy of machine spindle
Materiale   Material	Acciaio legato, bonificato con carico di rottura di 800 N/mm <sup>2</sup> . Temprato secondo scala Vickers min. 630 HV10 (Min 56 HRC). Attacco e superficie di controllo sono rettificati. Alloyed case-hardened steel with a minimum tensile strength of 800N/mm <sup>2</sup> . Carbonized accord. Vickers min. 630 HV10 (min. 56 HRC). Shank and controll surface are grinded.
Run Out	3 µm max.
Caratteristiche   Features	Con tiranti speciali può essere utilizzabile su (MAS403 - BT) - (DIN 2080). With special studs they can be used for (MAS403 - BT) - (DIN 2080).
Accessori e Ricambi a richiesta Accessories & Spare parts on request	Tiranti (vedi pagina 260-261)   Pull Studs (see page 260-261)

Codice d'ordine Order Code	STATUS	SK	A	I <sub>4</sub>	D
<b>ISOCK 40</b>					
ISOCK 40X30	●	40	300	289	30
<b>ISOCK 50</b>					
ISOCK 50X36	●	50	300	287	36



p. 072-074

## BTCL

Calettamento a Caldo  
"Standard"  
Shrink Fit Holders  
"Standard"



NEW

p. 075-076

## BTCLS

Calettamento a Caldo  
"Slim"  
Shrink Fit Holders  
"Slim"



p. 077-078

## BTID

Serraggio Idraulico  
Hydraulic Chucks



p. 079-080

## BTFS

Forte Serraggio  
Power Milling Chucks



NEW

p. 081-082

## BTTF

Porta Testine Filettate  
(Tipo Conico)  
Screwed Milling Cutters  
(Tapered Type)



p. 083-085

## BTER

Portapinze ER  
(DIN 6499)  
Collet Chucks ER  
(DIN 6499)



NEW

p. 086-087

## BTERM

Portapinze ER MINI  
(DIN 6499)  
Collet Chucks ER MINI  
(DIN 6499)



p. 088-089

## BTOZ

Portapinze OZ  
(DIN 6388)  
Collet Chuck OZ  
(DIN 6388)



p. 090-093

## BTWE

Attacco Weldon  
Weldon Holders



NEW

p. 094-095

## BTWEG

Attacco Weldon con  
Canalini di Lubrificazione  
Weldon Holders with  
Coolant Grooves



p. 096-097

## BTWN

Attacco Whistle Notch  
Whistle-Notch Holders



p. 098-099

## BTFI

Portafrese Fissi  
(DIN 6357)  
Shell End Mill Holders  
(DIN 6357)

# MAS403 - BT

# B

Indice di sezione | Section Index



p. 100-102

## BTAC

Portafrese Combinati  
(DIN 6358)  
Combi Shell End Mill Holders  
(DIN 6358)



p. 103

## BTAS

Portapunte Autoserranti  
(Standard)  
Drill Chucks  
(Standard)



p. 104-105

## BTDS

Portapunte Autoserranti  
(Alta Precisione)  
Drill Chucks  
(High Precision)



p. 106-107

## BTMS

Porta Maschi  
Tapping Chucks



p. 108-109

## BTCM

Attacco Cono Morse  
per Punte (DIN 6383)  
Morse Taper  
for Drills (DIN 6383)



p. 110-111

## BTMK

Attacco Cono Morse  
per Frese (DIN 6364)  
Morse Taper  
for End Mills (DIN 6364)



p. 112-113

## BTD

Attacco Conico  
(DIN 238)  
Taper Shafts  
(DIN 238)



NEW

p. 114

## BTMR

Mandri di Riduzione  
Reduction Arbor



NEW

p. 115

## BTSL

Semi Lavorato  
Blank Bars

# BTCL

## CALETTAMENTO A CALDO "STANDARD" SHRINK FIT HOLDERS "STANDARD"

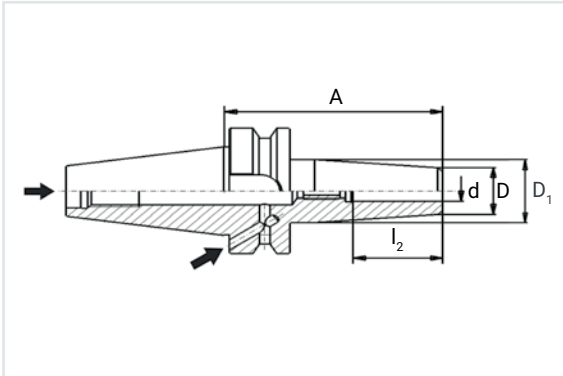

### Dettagli tecnici | Technical details

Applicazione | Application

Per utensili con codolo cilindrico in tolleranza h6  
For tools with cylindrical shank with h6 tolerance

Forma | Form

AD/B

Grado di bilanciatura | Degree of balancing

G 2.5 20.000 giri/min | G 2.5 20.000 rpm

Run Out

Max. 3 µm

Accessori forniti | Accessories provided

-

Elenco Accessori e Ricambi a richiesta  
List of Accessories & Spare parts on request

Vedi pagina 74 | See page 74

Codice d'ordine  
Order Code

STATUS

SK	d	A	l <sub>2</sub>	D	D <sub>1</sub>
----	---	---	----------------	---	----------------

#### BTCL 40

BTCL 40X3X90	NEW ●
BTCL 40X4X90	NEW ●
BTCL 40X5X90	NEW ●
BTCL 40X6X90	●
BTCL 40X6X120	NEW ●
BTCL 40X6X160	NEW ●
BTCL 40X8X90	●

40	3	90	-	12	20
40	4	90	-	15	22
40	5	90	-	15	22
40	6	90	36	20	27
40	6	120	36	20	27
40	6	160	36	20	27
40	8	90	36	20	27

La gamma prosegue nella pagina successiva | The range continues on the next page >>



Codice d'ordine Order Code	STATUS	SK	d	A	I <sub>2</sub>	D	D <sub>1</sub>
<b>BTCL 40</b>							
BTCL 40X8X120	NEW ●	40	8	120	36	20	27
BTCL 40X8X160	NEW ●	40	8	160	36	20	27
BTCL 40X10X90	●	40	10	90	42	24	32
BTCL 40X10X120	NEW ●	40	10	120	42	24	32
BTCL 40X10X160	NEW ●	40	10	160	42	24	32
BTCL 40X12X90	●	40	12	90	47	24	32
BTCL 40X12X120	NEW ●	40	12	120	47	24	32
BTCL 40X12X160	NEW ●	40	12	160	47	24	32
BTCL 40X14X90	●	40	14	90	48	27	34
BTCL 40X14X120	NEW ●	40	14	120	48	27	34
BTCL 40X14X160	NEW ●	40	14	160	48	27	34
BTCL 40X16X90	●	40	16	90	51	27	34
BTCL 40X16X120	NEW ●	40	16	120	51	27	34
BTCL 40X16X160	NEW ●	40	16	160	51	27	34
BTCL 40X18X90	●	40	18	90	51	33	42
BTCL 40X18X120	NEW ●	40	18	120	51	33	42
BTCL 40X18X160	NEW ●	40	18	160	51	33	42
BTCL 40X20X90	●	40	20	90	53	33	42
BTCL 40X20X120	NEW ●	40	20	120	53	33	42
BTCL 40X20X160	NEW ●	40	20	160	53	33	42
BTCL 40X25X100	●	40	25	100	58	44	53
BTCL 40X25X160	NEW ●	40	25	160	58	44	53
BTCL 40X32X100	●	40	32	100	58	44	53
<b>BTCL 50</b>							
BTCL 50X6X100	●	50	6	100	36	21	27
BTCL 50X8X100	●	50	8	100	36	21	27
BTCL 50X10X100	●	50	10	100	42	24	32
BTCL 50X12X100	●	50	12	100	47	24	32
BTCL 50X14X100	●	50	14	100	47	27	34
BTCL 50X16X100	●	50	16	100	50	27	34
BTCL 50X18X100	●	50	18	100	50	33	42
BTCL 50X20X100	●	50	20	100	52	33	42
BTCL 50X25X110	●	50	25	110	58	44	53
BTCL 50X32X110	●	50	32	110	62	44	53

Accessori e Ricambi alla pagina successiva | Accessories and Spare Parts on the next page >>

**Accessori e Ricambi | Accessories & Spare Parts**

	Codice Code	Pagina Page
<b>01 PROLUNGHE PER CALETTAMENTO A CALDO   SHRINK FIT EXTENSIONS</b>		
Standard	PRCL	p. 200
<b>02 TIRANTI - MAS403 BT   PULL STUDS - MAS403 BT</b>		
Con foro di lubrificazione   With bore	TRBTC	p. 266
Senza foro di lubrificazione   Without bore	TRBTS	p. 267

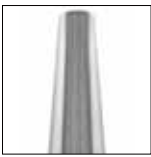

01



02

## BTCLS

### CALETTAMENTO A CALDO "SLIM" SHRINK FIT HOLDERS "SLIM"

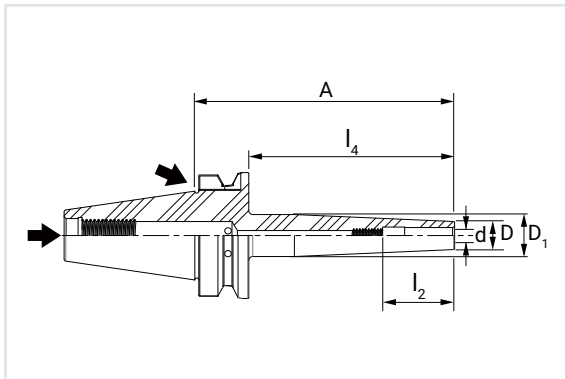

#### Dettagli tecnici | Technical details

Applicazione   Application	Per utensili con codolo cilindrico in tolleranza h6 For tools with cylindrical shank with h6 tolerance
Forma   Form	AD/B
Grado di bilanciatura   Degree of balancing	G 2.5 25.000 giri/min   G 2.5 25.000 rpm
Run Out	Max. 3 µm
Accessori forniti   Accessories provided	-
Elenco Accessori e Ricambi a richiesta List of Accessories & Spare parts on request	Vedi pagina 76   See page 76

Codice d'ordine Order Code	STATUS	SK	d	A	l <sub>2</sub>	l <sub>4</sub>	D	D <sub>1</sub>
<b>BTCLS 40</b>								
BTCLS 40X6X90	NEW ●	40	6	90	36	63	12	17
BTCLS 40X6X130	NEW ●	40	6	130	36	103	12	19
BTCLS 40X6X160	NEW ●	40	6	160	36	133	12	19
BTCLS 40X8X90	NEW ●	40	8	90	36	63	14	19
BTCLS 40X8X130	NEW ●	40	8	130	36	103	14	21
BTCLS 40X8X160	NEW ●	40	8	160	36	133	14	21
BTCLS 40X10X90	NEW ●	40	10	90	42	63	16	21

La gamma prosegue nella pagina successiva | The range continues on the next page >>

Codice d'ordine Order Code	STATUS	SK	d	A	I <sub>2</sub>	I <sub>4</sub>	D	D <sub>1</sub>
<b>BTCLS 40</b>								
BTCLS 40X10X130	NEW ●	40	10	130	42	103	16	23
BTCLS 40X10X160	NEW ●	40	10	160	42	133	16	23
BTCLS 40X12X90	NEW ●	40	12	90	46	63	18	23
BTCLS 40X12X130	NEW ●	40	12	130	47	103	18	25
BTCLS 40X12X160	NEW ●	40	12	160	47	133	18	25
BTCLS 40X14X90	NEW ●	40	14	90	47	63	20	25
BTCLS 40X14X130	NEW ●	40	14	130	47	103	20	27
BTCLS 40X14X160	NEW ●	40	14	160	47	133	20	27
BTCLS 40X16X90	NEW ●	40	16	90	49	63	24	29
BTCLS 40X16X130	NEW ●	40	16	130	49	103	24	31
BTCLS 40X16X160	NEW ●	40	16	160	49	133	24	31
BTCLS 40X20X90	NEW ●	40	20	90	51	63	28	33
BTCLS 40X20X130	NEW ●	40	20	130	51	103	28	35
BTCLS 40X20X160	NEW ●	40	20	160	51	133	28	35

Accessori e Ricambi | Accessories & Spare Parts

	Codice Code	Pagina Page
<b>01 TIRANTI - MAS403 BT   PULL STUDS - MAS403 BT</b>		
Con foro di lubrificazione   With bore	TRBTC	p. 266
Senza foro di lubrificazione   Without bore	TRBTS	p. 267



01

## BTID

### SERRAGGIO IDRAULICO HYDRAULIC CHUCKS

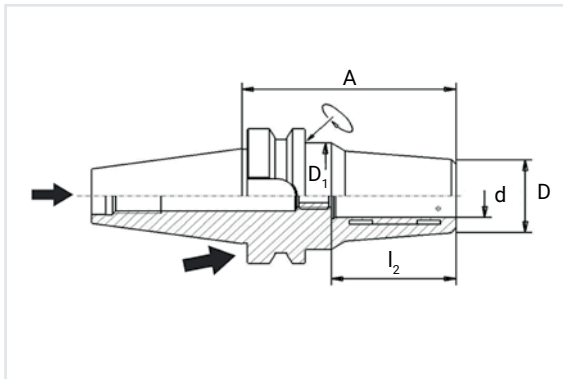

#### Dettagli tecnici | Technical details

Applicazione   Application	Per utensili con codolo cilindrico secondo norma DIN 6535 HA-HB, in tolleranza h6 For tools with cylindrical shank according to DIN 6535 HA-HB, with h6 tolerance.
Forma   Form	AD/B
Grado di bilanciatura   Degree of balancing	G 2.5 20.000 giri/min   G 2.5 20.000 rpm
Run Out	Max. 3 µm
Accessori forniti   Accessories provided	Chiave   Wrench
Elenco Accessori e Ricambi a richiesta List of Accessories & Spare parts on request	Vedi pagina 78   See page 78

Codice d'ordine Order Code	STATUS	SK	d	A	l <sub>2</sub>	D	D <sub>1</sub>
<b>BTID 40</b>							
BTID 40X12	●	40	12	90	40	32	49,5
BTID 40X16	●	40	16	90	46	38	49,5
BTID 40X20	●	40	20	90	46	40	49,5
BTID 40X25	●	40	25	90	63	50	55
BTID 40X32	●	40	32	90	63	56	63

La gamma prosegue nella pagina successiva | The range continues on the next page >>

Codice d'ordine Order Code	STATUS	SK	d	A	l <sub>2</sub>	D	D <sub>1</sub>
<b>BTID 50</b>							
BTID 50X20	●	50	20	110	51	42	49,5
BTID 50X25	●	50	25	110	57	55	63
<b>BTIDE 40</b> (Versione corta, idonea alle lavorazioni di sgrossatura pesante in fresatura   Short version, suitable for heavy roughing operations in milling)							
BTIDE 40X20	●	40	20	72,5	46	40	49,5
<b>BTIDE 50</b> (Versione corta, idonea alle lavorazioni di sgrossatura pesante in fresatura   Short version, suitable for heavy roughing operations in milling)							
BTIDE 50X32	●	50	32	90	61	60	72

Accessori e Ricambi | Accessories & Spare Parts

	Codice Code	Pagina Page
<b>01 BUSSOLE DI RIDUZIONE   REDUCTION SLEEVE</b>		
Standard	BSID	p. 248
<b>02 PROLUNGHE PER CALETTAMENTO A CALDO   SHRINK FIT EXTENSIONS</b>		
Standard	PRCL	p. 200
<b>02 TIRANTI - MAS403 BT   PULL STUDS - MAS403 BT</b>		
Con foro di lubrificazione   With bore	TRBTC	p. 266
Senza foro di lubrificazione   Without bore	TRBTS	p. 267



01

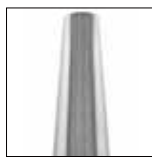

02



03

## BTFS

### FORTE SERRAGGIO POWER MILLING CHUCKS

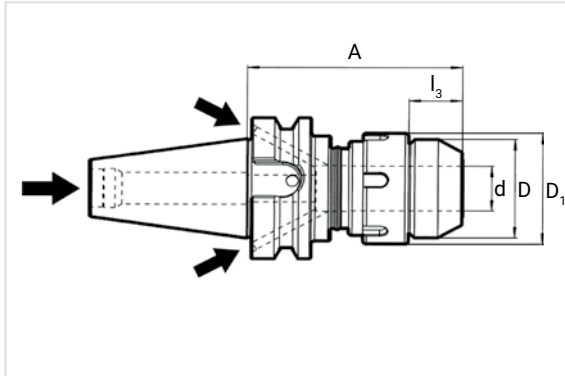

#### Dettagli tecnici | Technical details

Applicazione | Application

Forma | Form

Grado di bilanciatura | Degree of balancing

Run Out

Accessori forniti | Accessories provided

Elenco Accessori e Ricambi a richiesta  
List of Accessories & Spare parts on request

Per utensili con codolo cilindrico in differenti tolleranze  
For tools with cylindrical shank in different tolerances

AD/B

G 2.5 20.000 giri/min | G 2.5 20.000 rpm

Max. 4  $\mu\text{m}$  (3 x d)

Chiave | Wrench

Vedi pagina 80 | See page 80

Codice d'ordine  
Order Code

STATUS

#### BTFS 40

BTFS 40X20X90	NEW TECH ●
BTFS 40X20X150	NEW TECH ●
BTFS 40X32X95	NEW TECH ●
BTFS 40X32X150	NEW TECH ●

SK	d	l <sub>1</sub>	l <sub>3</sub>	D	D <sub>1</sub>
40	20	90	23	46	49
40	20	150	23	46	49
40	32	95	33	67	68
40	32	150	33	67	68

La gamma prosegue nella pagina successiva | The range continues on the next page >>

Codice d'ordine Order Code	STATUS	SK	d	l <sub>1</sub>	l <sub>3</sub>	D	D <sub>1</sub>
<b>BTFS 50</b>							
BTFS 50X20X100	NEW TECH ●	50	20	100	23	46	49
BTFS 50X20X150	NEW TECH ●	50	20	150	23	46	49
BTFS 50X32X95	■	50	32	95	33	67	68
BTFS 50X32X110	NEW TECH ●	50	32	110	33	67	68
BTFS 50X32X150	NEW TECH ●	50	32	150	33	67	68

■ Fino ad esaurimento scorte | Till stocks last

Forza e coppia di serraggio | Tightening force and torque

Diametro utensile Tool diameter	Coppia di serraggio massima Maximum tightening torque	Forza di serraggio Clamping force
6	60 Nm	150 Nm
8	60 Nm	180 Nm
10	80 Nm	320 Nm
12	80 Nm	380 Nm
16	100 Nm	400 Nm
20	100 Nm	520 Nm
25	150 Nm	550 Nm
32	150 Nm	800 Nm

Esempio: Il mandrino deve essere bloccato tramite una chiave dinamometrica con coppia di serraggio massima di 60 Nm per raggiungere una forza di serraggio sul codolo alloggiato di 150 Nm.

Example: you should clamp the chuck with a tightening-torque-wrench with the maximum tightening torque of 60 Nm (maximum), to reach a clamping force on the clamped shaft of 150 Nm.

Accessori e Ricambi | Accessories & Spare Parts

	Codice Code	Pagina Page
<b>01 BUSSOLE DI RIDUZIONE   REDUCTION SLEEVE</b>		
Standard	BSFS	p. 246
<b>02 TIRANTI - MAS403 BT   PULL STUDS - MAS403 BT</b>		
Con foro di lubrificazione   With bore	TRBTC	p. 266
Senza foro di lubrificazione   Without bore	TRBTS	p. 267



01



02



## BTTF

### PORTA TESTINE FILETTATE (TIPO CONICO) SCREWED MILLING CUTTERS (TAPERED TYPE)

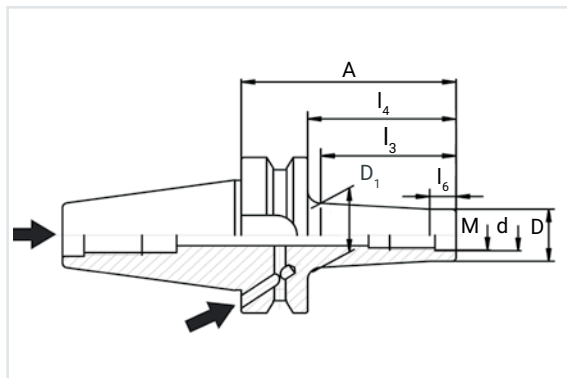

#### Dettagli tecnici | Technical details

Applicazione | Application

Per frese con attacco filettato  
For end mills with threaded shank

Forma | Form

AD/B

Grado di bilanciatura | Degree of balancing

G 6.3 15.000 giri/min | G 6.3 15.000 rpm

Run Out

-

Accessori forniti | Accessories provided

-

Elenco Accessori e Ricambi a richiesta  
List of Accessories & Spare parts on request

Vedi pagina 82 | See page 82

Codice d'ordine  
Order Code

STATUS

SK

d

A

M

l<sub>3</sub>

l<sub>4</sub>

l<sub>6</sub>

D

D<sub>1</sub>

#### BTTF 40

BTTF 40XM6X52	NEW ●	40	6,5	52	M6	22	25	-	10	13
BTTF 40XM6X77	NEW ●	40	6,5	77	M6	47	50	-	10	20
BTTF 40XM6X102	NEW ●	40	6,5	102	M6	72	75	-	10	23
BTTF 40XM8X52	NEW ●	40	8,5	52	M8	24	25	10	13	18
BTTF 40XM8X77	NEW ●	40	8,5	77	M8	48	50	10	13	23
BTTF 40XM8X102	NEW ●	40	8,5	102	M8	65	75	10	13	20
BTTF 40XM8X127	NEW ●	40	8,5	127	M8	95	100	10	13	25

La gamma prosegue nella pagina successiva | The range continues on the next page >>

Codice d'ordine Order Code	STATUS	SK	d	A	M	l <sub>3</sub>	l <sub>4</sub>	l <sub>6</sub>	D	D <sub>1</sub>
<b>BTTF 40</b>										
BTTF 40XM10X52	NEW ●	40	10,5	52	M10	23	25	10	18	20
BTTF 40XM10X77	NEW ●	40	10,5	77	M10	45	50	10	18	23
BTTF 40XM10X102	NEW ●	40	10,5	102	M10	73	75	10	18	28
BTTF 40XM10X127	NEW ●	40	10,5	127	M10	90	100	10	18	30
BTTF 40XM12X52	NEW ●	40	12,5	52	M12	23	25	10	21	24
BTTF 40XM12X102	NEW ●	40	12,5	102	M12	73	75	10	21	31
BTTF 40XM12X152	NEW ●	40	12,5	152	M12	115	125	10	21	35
BTTF 40XM16X52	NEW ●	40	17	52	M16	23	25	10	29	29
BTTF 40XM16X102	NEW ●	40	17	102	M16	73	75	10	29	35
BTTF 40XM16X152	NEW ●	40	17	152	M16	115	125	10	29	38
<b>BTTF 50</b>										
BTTF 50XM8X88	NEW ●	50	8,5	88	M8	48	50	-	13	23
BTTF 50XM8X138	NEW ●	50	8,5	138	M8	96	100	-	13	30
BTTF 50XM8X188	NEW ●	50	8,5	188	M8	146	150	-	13	37
BTTF 50XM10X88	NEW ●	50	10,5	88	M10	48	50	10	18	23
BTTF 50XM10X138	NEW ●	50	10,5	138	M10	90	100	10	18	27
BTTF 50XM10X188	NEW ●	50	10,5	188	M10	147	150	10	18	37
BTTF 50XM12X88	NEW ●	50	12,5	88	M12	42	50	10	21	24
BTTF 50XM12X138	NEW ●	50	12,5	138	M12	90	100	10	21	33
BTTF 50XM12X188	NEW ●	50	12,5	188	M12	130	150	10	21	40
BTTF 50XM16X88	NEW ●	50	17	88	M16	42	50	10	29	34
BTTF 50XM16X138	NEW ●	50	17	138	M16	92	100	10	29	36
BTTF 50XM16X188	NEW ●	50	17	188	M16	130	150	10	29	43

Accessori e Ricambi | Accessories & Spare Parts

	Codice Code	Pagina Page
<b>01 TIRANTI - MAS403 BT   PULL STUDS - MAS403 BT</b>		
Con foro di lubrificazione   With bore	TRBTC	p. 266
Senza foro di lubrificazione   Without bore	TRBTS	p. 267
<b>02 PROLUNGHE PER PORTA TESTINE FILETTATE   EXTENSIONS FOR SCREWED MILLING CUTTERS</b>		
Standard	PRTF	p. 210
<b>03 RIDUZIONI PER PORTA TESTINE FILETTATE   REDUCTIONS FOR SCREWED MILLING CUTTERS</b>		
Standard	RTF	p. 283

## BTER-BTERB

### PORTAPINZE ER (DIN 6499) COLLET CHUCKS ER (DIN 6499)

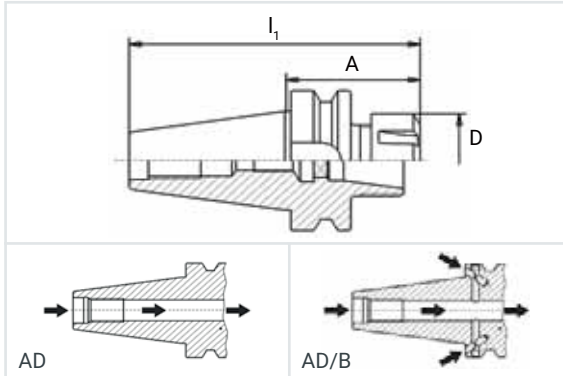

#### Dettagli tecnici | Technical details

Applicazione | Application

Forma | Form

Grado di bilanciatura | Degree of balancing

Run Out

Accessori forniti | Accessories provided

Elenco Accessori e Ricambi a richiesta  
List of Accessories & Spare parts on request

Per utensili con codolo cilindrico in differenti tolleranze  
For tools with cylindrical shank in different tolerances

AD - AD/B

G 6.3 15.000 giri/min | G 6.3 15.000 rpm

Max. 5 µm

Ghiera di bloccaggio standard | Standard clamp nut

Vedi pagina 85 | See page 85

Codice d'ordine  
Order Code

STATUS

#### BTER 30

BTER 30X16X70	●
BTER 30X16X100	●
BTER 30X25X70	●
BTER 30X32X70	●

#### BTER 40

BTER 40X16X60	●
---------------	---

SK	ER	A	l <sub>1</sub>	D	Forma Form
30	16	70	118	32	AD
30	16	100	148	32	AD
30	25	70	118	42	AD
30	32	70	118	50	AD
40	16	60	126	32	AD

La gamma prosegue nella pagina successiva | The range continues on the next page >>

Codice d'ordine Order Code	STATUS
-------------------------------	--------

SK	ER	A	I <sub>1</sub>	D	Forma Form
----	----	---	----------------	---	---------------

**BTER 40**

BTER 40X16X100	●	40	16	100	166	32	AD
BTER 40X25X60	●	40	25	60	126	42	AD
BTER 40X25X100	●	40	25	100	166	42	AD
BTER 40X25X160	■	40	25	160	226	42	AD
BTER 40X32X60	●	40	32	60	126	50	AD
BTER 40X32X100	●	40	32	100	166	50	AD
BTER 40X32X160	■	40	32	160	226	50	AD
BTER 40X40X80	●	40	40	80	146	63	AD
BTER 40X40X120	●	40	40	120	186	63	AD
BTER 40X40X160	●	40	40	160	226	63	AD

**BTER 50**

BTER 50X25X70	NEW ●	50	25	70	172	42	AD
BTER 50X32X70	●	50	32	70	172	50	AD
BTER 50X32X160	●	50	32	160	262	50	AD
BTER 50X40X80	●	50	40	80	182	63	AD

**BTERB 40**

BTERB 40X16X60	NEW ●	40	16	60	126	32	AD/B
BTERB 40X16X100	NEW ●	40	16	100	166	32	AD/B
BTERB 40X16X160	NEW ●	40	16	160	226	32	AD/B
BTERB 40X25X60	NEW ●	40	25	60	126	42	AD/B
BTERB 40X25X100	NEW ●	40	25	100	166	42	AD/B
BTERB 40X25X160	NEW ●	40	25	160	226	42	AD/B
BTERB 40X32X60	NEW ●	40	32	60	126	50	AD/B
BTERB 40X32X100	NEW ●	40	32	100	166	50	AD/B
BTERB 40X32X160	NEW ●	40	32	160	226	50	AD/B
BTERB 40X40X80	NEW ●	40	40	80	146	63	AD/B
BTERB 40X40X160	NEW ●	40	40	160	226	63	AD/B

**BTERB 50**

BTERB 50X25X70	NEW ●	50	25	70	172	42	AD/B
BTERB 50X25X160	NEW ●	50	25	160	262	42	AD/B
BTERB 50X32X70	NEW ●	50	32	70	172	50	AD/B
BTERB 50X32X100	NEW ●	50	32	100	202	50	AD/B
BTERB 50X32X160	NEW ●	50	32	160	262	50	AD/B
BTERB 50X40X80	NEW ●	50	40	80	182	63	AD/B
BTERB 50X40X160	NEW ●	50	40	160	262	63	AD/B

■ Fino ad esaurimento scorte | Till stocks last

## Accessori e Ricambi | Accessories & Spare Parts

	Codice Code	Pagina Page
<b>01 PINZE ER   ER COLLETS</b>		
Standard	PZER	p. 216
Ultra precise   High precision	ERUP	p. 223
Vulcanizzate   Rubber sealed collets	ERVU	p. 229
Con quadro interno   With internal square	PZSQ	p. 233
A tenuta con fori di lubrificazione   Externally cooled collets	PZERJ	p. 236
<b>02 GHIERA DI BLOCCAGGIO ER   ER CLAMP NUT</b>		
Standard	GRERB	p. 256
Bilanciata   Balanced	GRERC	p. 256
Per forte serraggio   For high clamping power	GRERD	p. 257
Con anello di tenuta   With sealing disk	GRERE	p. 257
Con anello di tenuta a step di 0.5 mm   With sealing disk in 0.5 mm steps	GRERF	p. 257
<b>03 CHIAVE DI BLOCCAGGIO ER   ER WRENCH CLAMP</b>		
Standard	CVER	p. 277
<b>04 TIRANTI - MAS403 BT   PULL STUDS - MAS403 BT</b>		
Con foro di lubrificazione   With bore	TRBTC	p. 266
Senza foro di lubrificazione   Without bore	TRBTS	p. 267
<b>05 PROLUNGHE CILINDRICHE PER PORTA PINZE ER   CYLINDRICAL EXTENSIONS FOR ER COLLET CHUCKS</b>		
Standard	PGCL	p. 202



01



02



03



04



05

**BTERM**

**PORTAPINZE ER MINI (DIN 6499)**  
**COLLET CHUCKS ER MINI (DIN 6499)**

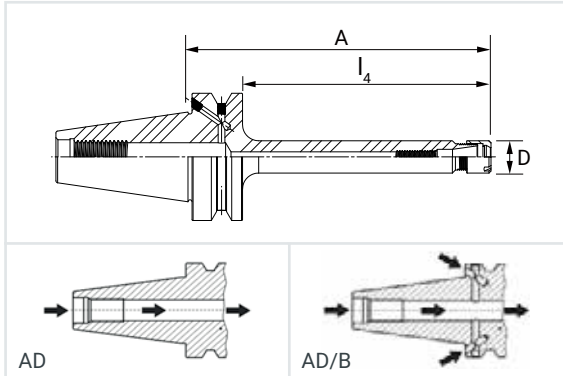

**Dettagli tecnici | Technical details**

Applicazione | Application

Per utensili con codolo cilindrico in differenti tolleranze  
For tools with cylindrical shank in different tolerances

Forma | Form

AD - AD/B

Grado di bilanciatura | Degree of balancing

G 6.3 15.000 giri/min | G 6.3 15.000 rpm

Run Out

Max. 5 µm

Accessori forniti | Accessories provided

Ghiera di bloccaggio mini | Mini clamp nut

Elenco Accessori e Ricambi a richiesta  
List of Accessories & Spare parts on request

Vedi pagina 87 | See page 87

Codice d'ordine Order Code	STATUS
-------------------------------	--------

SK	ER	A	I <sub>4</sub>	D	Forma Form
----	----	---	----------------	---	---------------

**BTERM 30**

BTERM 30X11X60	NEW ●
BTERM 30X11X100	NEW ●
BTERM 30X16X60	NEW ●
BTERM 30X16X100	NEW ●
BTERM 30X16X120	NEW ●

30	11	60	38	16	AD
30	11	100	78	16	AD
30	16	60	38	22	AD
30	16	100	78	22	AD
30	16	120	98	22	AD

**BTERM 40**

BTERM 40X11X100	NEW ●
-----------------	-------

40	11	100	73	16	AD/B
----	----	-----	----	----	------

La gamma prosegue nella pagina successiva | The range continues on the next page >>

Codice d'ordine Order Code	STATUS	SK	ER	A	I <sub>4</sub>	D	Forma Form
<b>BTERM 40</b>							
BTERM 40X11X125	NEW ●	40	11	125	98	16	AD/B
BTERM 40X11X130	NEW ●	40	11	130	103	16	AD/B
BTERM 40X11X150	NEW ●	40	11	150	123	16	AD/B
BTERM 40X16X100	NEW ●	40	16	100	73	22	AD/B
BTERM 40X16X125	NEW ●	40	16	125	98	22	AD/B
BTERM 40X16X150	NEW ●	40	16	150	123	22	AD/B
BTERM 40X20X100	NEW ●	40	20	100	73	28	AD/B
BTERM 40X20X130	NEW ●	40	20	130	103	28	AD/B
BTERM 40X20X150	NEW ●	40	20	150	123	28	AD/B
BTERM 40X25X100	NEW ●	40	25	100	73	35	AD/B
BTERM 40X25X150	NEW ●	40	25	150	123	35	AD/B
<b>BTERM 50</b>							
BTERM 50X16X130	NEW ●	50	16	130	92	22	AD/B
BTERM 50X16X160	NEW ●	50	16	160	122	22	AD/B
BTERM 50X16X200	NEW ●	50	16	200	162	22	AD/B

## Accessori e Ricambi | Accessories & Spare Parts

	Codice Code	Pagina Page
<b>01 PINZE ER   ER COLLETS</b>		
Standard	PZER	p. 216
Ultra precise   High precision	ERUP	p. 223
Vulcanizzate   Rubber sealed collets	ERVU	p. 229
Con quadro interno   With internal square	PZSQ	p. 233
A tenuta con fori di lubrificazione   Externally cooled collets	PZERJ	p. 236
<b>02 GHIERA DI BLOCCAGGIO ER   ER CLAMP NUT</b>		
Mini	GRERA	p. 256
<b>03 CHIAVE DI BLOCCAGGIO ER   ER WRENCH CLAMP</b>		
Mini	CVERM	p. 277
<b>04 TIRANTI - MAS403 BT   PULL STUDS - MAS403 BT</b>		
Con foro di lubrificazione   With bore	TRBTC	p. 266
Senza foro di lubrificazione   Without bore	TRBTS	p. 267
<b>05 PROLUNGHE PER PORTA PINZE ER (MINI)   EXTENSIONS FOR ER COLLET CHUCKS (MINI)</b>		
Prolunghe Cilindriche   Cylindrical Extensions	PGCLM	p. 204
Prolunghe Weldon   Weldon Extensions	PGWEM	p. 208

**BTOZ**

**PORTAPINZE OZ (DIN 6388)  
COLLET CHUCKS OZ (DIN 6388)**

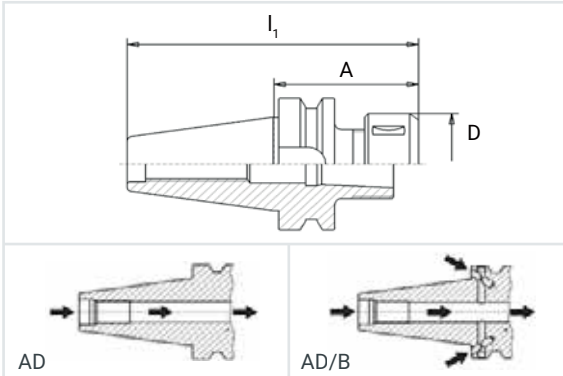

**Dettagli tecnici | Technical details**

Applicazione | Application

Forma | Form

Grado di bilanciatura | Degree of balancing

Run Out

Accessori forniti | Accessories provided

Elenco Accessori e Ricambi a richiesta  
List of Accessories & Spare parts on request

Per utensili con codolo cilindrico in differenti tolleranze  
For tools with cylindrical shank in different tolerances

AD

G 6.3 15.000 giri/min | G 6.3 15.000 rpm

Max. 5 µm

Ghiera di bloccaggio standard | Standard clamp nut

Vedi pagina 89 | See page 89

Codice d'ordine  
Order Code STATUS

**BTOZ 30**

BTOZ 30X16X60	●
BTOZ 30X25X80	●

**BTOZ 40**

BTOZ 40X16X70	●
BTOZ 40X25X70	●
BTOZ 40X32X90	●

SK	OZ	A	L <sub>1</sub>	D
30	16	60	108	43
30	25	80	128	60
40	16	70	136	43
40	25	70	136	60
40	32	90	156	72

La gamma prosegue nella pagina successiva | The range continues on the next page >>



Codice d'ordine Order Code	STATUS	SK	OZ	A	I <sub>1</sub>	D
<b>BTOZ 50</b>						
BTOZ 50X25X85	●	50	25	85	187	60
BTOZ 50X32X90	●	50	32	90	192	72

## Accessori e Ricambi | Accessories & Spare Parts

	Codice Code	Pagina Page
<b>01 PINZE OZ   OZ COLLETS</b>		
Standard	PZOZ	p. 239
<b>02 GHIERA DI BLOCCAGGIO OZ   OZ CLAMP NUT</b>		
Standard	GRID1	p. 258
Bilanciato   Balanced	GRID2	p. 258
Con canali di lubrificazione   With coolant channels	GRID3	p. 258
Con anello di tenuta   With sealing disk	GRID4	p. 258
<b>03 CHIAVE DI BLOCCAGGIO OZ   OZ WRENCH CLAMP</b>		
Standard	CVOZ	p. 278
<b>04 TIRANTI - MAS403 BT   PULL STUDS - MAS403 BT</b>		
Con foro di lubrificazione   With bore	TRBTC	p. 266
Senza foro di lubrificazione   Without bore	TRBTS	p. 267
<b>05 PROLUNGHE CILINDRICHE PER PORTA PINZE ER   CYLINDRICAL EXTENSIONS FOR ER COLLET CHUCKS</b>		
Standard	PGCL	p. 202



01



02



03



04



05

**BTWE - BTWEB**

**ATTACCO WELDON  
WELDON HOLDERS**

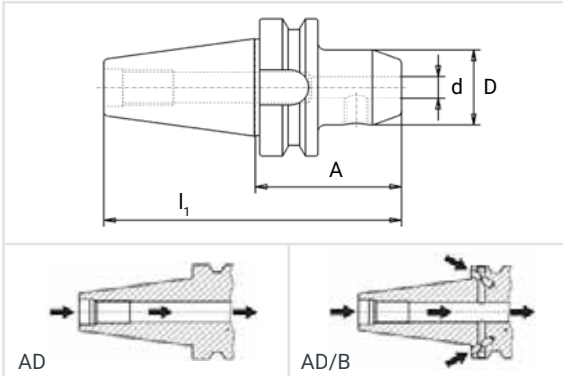

**Dettagli tecnici | Technical details**

Applicazione | Application

Forma | Form

Grado di bilanciatura | Degree of balancing

Run Out

Accessori forniti | Accessories provided

Elenco Accessori e Ricambi a richiesta  
List of Accessories & Spare parts on request

Per utensili con codolo cilindrico tipo weldon secondo norma DIN 1835B.  
For tools with weldon type cylindrical shank according to DIN 1835B.

AD - AD/B

G 6.3 15.000 giri/min | G 6.3 15.000 rpm

Max. 15 µm (3 x d)

Vite di bloccaggio | Clamping screw

Vedi pagina 93 | See page 93

Codice d'ordine  
Order Code STATUS

**BTWE 30**

BTWE 30X6X50	●
BTWE 30X8X50	●
BTWE 30X10X50	●
BTWE 30X12X50	●
BTWE 30X14X50	●
BTWE 30X16X63	●
BTWE 30X20X63	●

SK	d	A	l <sub>1</sub>	D	Forma Form
30	6	50	98	25	AD
30	8	50	98	28	AD
30	10	50	98	35	AD
30	12	50	98	42	AD
30	14	50	98	42	AD
30	16	63	111	48	AD
30	20	63	111	52	AD

La gamma prosegue nella pagina successiva | The range continues on the next page >>

Codice d'ordine Order Code	STATUS	SK	d	A	I <sub>1</sub>	D	Forma Form
<b>BTWE 40</b>							
BTWE 40X6X50	●	40	6	50	116	25	AD
BTWE 40X6X100	●	40	6	100	166	25	AD
BTWE 40X6X160	NEW ●	40	6	160	226	25	AD
BTWE 40X8X50	●	40	8	50	116	28	AD
BTWE 40X8X100	●	40	8	100	166	28	AD
BTWE 40X8X160	NEW ●	40	8	160	226	28	AD
BTWE 40X10X63	●	40	10	63	129	35	AD
BTWE 40X10X100	●	40	10	100	166	35	AD
BTWE 40X10X160	NEW ●	40	10	160	226	35	AD
BTWE 40X12X63	●	40	12	63	129	42	AD
BTWE 40X12X100	●	40	12	100	166	42	AD
BTWE 40X12X160	NEW ●	40	12	160	226	42	AD
BTWE 40X14X63	●	40	14	63	129	42	AD
BTWE 40X14X100	NEW ●	40	14	100	166	42	AD
BTWE 40X16X63	●	40	16	63	129	48	AD
BTWE 40X16X100	●	40	16	100	166	48	AD
BTWE 40X16X160	NEW ●	40	16	160	226	48	AD
BTWE 40X18X63	●	40	18	63	129	48	AD
BTWE 40X20X63	●	40	20	63	129	52	AD
BTWE 40X20X100	●	40	20	100	166	52	AD
BTWE 40X20X160	NEW ●	40	20	160	226	52	AD
BTWE 40X25X35	●	40	25	35	101	65	AD
BTWE 40X25X100	●	40	25	100	166	63	AD
BTWE 40X32X100	●	40	32	100	166	70	AD
BTWE 40X40X120	●	40	40	120	176	80	AD
<b>BTWE 50</b>							
BTWE 50X6X63	●	50	6	63	165	25	AD
BTWE 50X6X160	NEW ●	50	6	160	262	25	AD
BTWE 50X8X63	●	50	8	63	165	28	AD
BTWE 50X8X160	NEW ●	50	8	160	262	28	AD
BTWE 50X10X63	●	50	10	63	165	35	AD
BTWE 50X10X160	NEW ●	50	10	160	262	35	AD
BTWE 50X12X80	●	50	12	80	182	42	AD
BTWE 50X12X160	NEW ●	50	12	160	262	42	AD
BTWE 50X14X80	●	50	14	80	182	42	AD
BTWE 50X16X80	●	50	16	80	182	48	AD
BTWE 50X16X160	NEW ●	50	16	160	262	48	AD
BTWE 50X18X80	●	50	18	80	182	48	AD
BTWE 50X20X80	●	50	20	80	182	52	AD
BTWE 50X20X100	NEW ●	50	20	100	202	52	AD
BTWE 50X20X160	NEW ●	50	20	160	262	52	AD

La gamma prosegue nella pagina successiva | The range continues on the next page >>

Codice d'ordine Order Code	STATUS
-------------------------------	--------

SK	d	A	I <sub>1</sub>	D	Forma Form
----	---	---	----------------	---	---------------

**BTWE 50**

BTWE 50X25X100	●
BTWE 50X25X160	NEW ●
BTWE 50X32X105	●
BTWE 50X32X160	NEW ●
BTWE 50X40X120	●

50	25	100	202	63	AD
50	25	160	262	65	AD
50	32	105	207	70	AD
50	32	160	262	72	AD
50	40	120	222	80	AD

**BTWEB 40**

BTWEB 40X6X50	NEW ●
BTWEB 40X6X100	NEW ●
BTWEB 40X6X160	NEW ●
BTWEB 40X8X50	NEW ●
BTWEB 40X8X100	NEW ●
BTWEB 40X8X160	NEW ●
BTWEB 40X10X63	NEW ●
BTWEB 40X10X100	NEW ●
BTWEB 40X10X160	NEW ●
BTWEB 40X12X63	NEW ●
BTWEB 40X12X100	NEW ●
BTWEB 40X12X160	NEW ●
BTWEB 40X14X63	NEW ●
BTWEB 40X14X100	NEW ●
BTWEB 40X16X63	NEW ●
BTWEB 40X16X100	NEW ●
BTWEB 40X16X160	NEW ●
BTWEB 40X18X63	NEW ●
BTWEB 40X18X100	NEW ●
BTWEB 40X20X63	NEW ●
BTWEB 40X20X100	NEW ●
BTWEB 40X20X160	NEW ●
BTWEB 40X25X100	NEW ●
BTWEB 40X25X160	NEW ●
BTWEB 40X32X100	NEW ●
BTWEB 40X32X160	NEW ●
BTWEB 40X40X120	NEW ●

40	6	50	116	25	AD/B
40	6	100	166	25	AD/B
40	6	160	226	25	AD/B
40	8	50	116	28	AD/B
40	8	100	166	28	AD/B
40	8	160	226	28	AD/B
40	10	63	129	35	AD/B
40	10	100	166	35	AD/B
40	10	160	226	35	AD/B
40	12	63	129	42	AD/B
40	12	100	166	42	AD/B
40	12	160	226	42	AD/B
40	14	63	129	42	AD/B
40	14	100	166	42	AD/B
40	16	63	129	48	AD/B
40	16	100	166	48	AD/B
40	16	160	226	48	AD/B
40	18	63	129	48	AD/B
40	18	100	166	48	AD/B
40	20	63	129	52	AD/B
40	20	100	166	52	AD/B
40	20	160	226	52	AD/B
40	25	100	166	63	AD/B
40	25	160	226	65	AD/B
40	32	100	166	70	AD/B
40	32	160	226	72	AD/B
40	40	120	176	80	AD/B

**BTWEB 50**

BTWEB 50X6X63	NEW ●
BTWEB 50X6X160	NEW ●
BTWEB 50X8X63	NEW ●
BTWEB 50X8X160	NEW ●
BTWEB 50X10X63	NEW ●
BTWEB 50X10X160	NEW ●

50	6	63	165	25	AD/B
50	6	160	262	25	AD/B
50	8	63	165	28	AD/B
50	8	160	262	28	AD/B
50	10	63	165	35	AD/B
50	10	160	262	35	AD/B

La gamma prosegue nella pagina successiva | The range continues on the next page >>

Codice d'ordine Order Code	STATUS	SK	d	A	l <sub>1</sub>	D	Forma Form
<b>BTWEB 50</b>							
BTWEB 50X12X80	NEW ●	50	12	80	182	42	AD/B
BTWEB 50X12X160	NEW ●	50	12	160	262	42	AD/B
BTWEB 50X14X80	NEW ●	50	14	80	182	42	AD/B
BTWEB 50X16X80	NEW ●	50	16	80	182	48	AD/B
BTWEB 50X16X160	NEW ●	50	16	160	262	48	AD/B
BTWEB 50X18X80	NEW ●	50	18	80	182	48	AD/B
BTWEB 50X20X80	NEW ●	50	20	80	182	52	AD/B
BTWEB 50X20X160	NEW ●	50	20	160	262	52	AD/B
BTWEB 50X25X100	NEW ●	50	25	100	202	63	AD/B
BTWEB 50X25X160	NEW ●	50	25	160	262	65	AD/B
BTWEB 50X32X105	NEW ●	50	32	105	207	70	AD/B
BTWEB 50X32X160	NEW ●	50	32	160	262	72	AD/B
BTWEB 50X40X120	NEW ●	50	40	120	222	80	AD/B

## Accessori e Ricambi | Accessories & Spare Parts

	Codice Code	Pagina Page
<b>01 MANDRINO A CAMBIO RAPIDO   QUICK CHANGE TAPPING CHUCK</b>		
Standard	WEMS	p. 284
<b>02 RIDUZIONI PER ATTACCO WELDON   REDUCTIONS FOR WELDON HOLDERS</b>		
Standard	RWE	p. 282
<b>03 PROLUNGHE WELDON PER PORTA PINZE ER   WELDON EXTENSIONS FOR ER COLLET CHUCKS</b>		
Standard	PGWE	p. 206
<b>04 VITE DI BLOCCAGGIO   CLAMPING SCREW</b>		
Standard	SWE ..	p. 280
<b>05 TIRANTI - MAS403 BT   PULL STUDS - MAS403 BT</b>		
Con foro di lubrificazione   With bore	TRBTC	p. 266
Senza foro di lubrificazione   Without bore	TRBTS	p. 267



01



02



03



04



05

**BTWEG**

**ATTACCO WELDON CON  
CANALINI DI LUBRIFICAZIONE  
WELDON HOLDERS WITH  
COOLANT GROOVES**

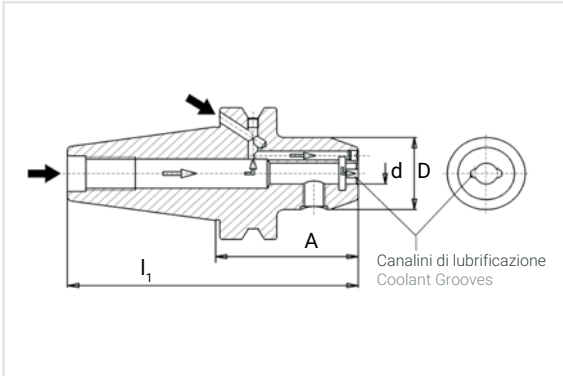

**Dettagli tecnici | Technical details**

Applicazione   Application	Per utensili con codolo cilindrico tipo weldon secondo norma DIN 1835B. For tools with weldon type cylindrical shank according to DIN 1835B.
Forma   Form	AD/B
Grado di bilanciatura   Degree of balancing	G 6.3 15.000 giri/min   G 6.3 15.000 rpm
Run Out	Max. 15 µm (3 x d)
Accessori forniti   Accessories provided	Vite di bloccaggio   Clamping screw
Elenco Accessori e Ricambi a richiesta List of Accessories & Spare parts on request	Vedi pagina 95   See page 95

Codice d'ordine Order Code	STATUS
-------------------------------	--------

**BTWEG 40**

BTWEG 40X6X50	NEW ●
BTWEG 40X8X50	NEW ●
BTWEG 40X10X63	NEW ●
BTWEG 40X12X63	NEW ●
BTWEG 40X14X63	NEW ●
BTWEG 40X16X63	NEW ●
BTWEG 40X18X63	NEW ●

SK	d	A	l <sub>1</sub>	D
40	6	50	116	25
40	8	50	116	28
40	10	63	129	35
40	12	63	129	42
40	14	63	129	44
40	16	63	129	48
40	18	63	129	50

La gamma prosegue nella pagina successiva | The range continues on the next page >>

Codice d'ordine Order Code	STATUS	SK	d	A	I <sub>1</sub>	D
<b>BTWEG 40</b>						
BTWEG 40X20X63	NEW ●	40	20	63	129	52
BTWEG 40X25X90	NEW ●	40	25	90	156	65
<b>BTWEG 50</b>						
BTWEG 50X6X63	NEW ●	50	6	63	165	25
BTWEG 50X8X63	NEW ●	50	8	63	165	28
BTWEG 50X10X63	NEW ●	50	10	63	165	35
BTWEG 50X12X80	NEW ●	50	12	80	182	42
BTWEG 50X14X80	NEW ●	50	14	80	182	44
BTWEG 50X16X80	NEW ●	50	16	80	182	48
BTWEG 50X18X80	NEW ●	50	18	80	182	50
BTWEG 50X20X80	NEW ●	50	20	80	182	52
BTWEG 50X25X100	NEW ●	50	25	100	202	65
BTWEG 50X32X105	NEW ●	50	32	105	207	72
BTWEG 50X40X120	NEW ●	50	40	120	222	80

## Accessori e Ricambi | Accessories & Spare Parts

	Codice Code	Pagina Page
<b>01 MANDRINO A CAMBIO RAPIDO   QUICK CHANGE TAPPING CHUCK</b>		
Standard	WEMS	p. 284
<b>02 RIDUZIONI PER ATTACCO WELDON   REDUCTIONS FOR WELDON HOLDERS</b>		
Standard	RWE	p. 282
<b>03 PROLUNGHE WELDON PER PORTA PINZE ER   WELDON EXTENSIONS FOR ER COLLET CHUCKS</b>		
Standard	PGWE	p. 206
<b>04 VITE DI BLOCCAGGIO   CLAMPING SCREW</b>		
Standard	SWE ..	p. 280
<b>05 TIRANTI - MAS403 BT   PULL STUDS - MAS403 BT</b>		
Con foro di lubrificazione   With bore	TRBTC	p. 266
Senza foro di lubrificazione   Without bore	TRBTS	p. 267



01



02



03



04



05

**BTWN**

**ATTACCO WHISTLE NOTCH  
WHISTLE-NOTCH HOLDERS**

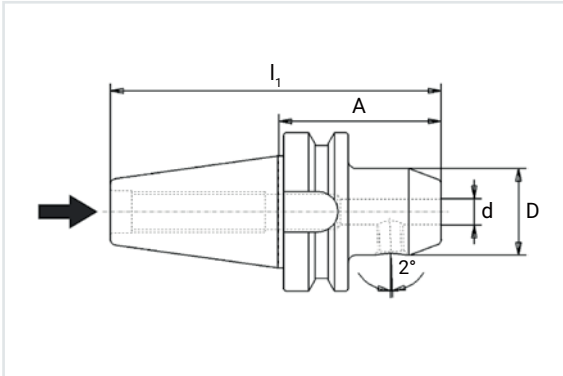

**Dettagli tecnici | Technical details**

Applicazione | Application

Forma | Form

Grado di bilanciatura | Degree of balancing

Run Out

Accessori forniti | Accessories provided

Elenco Accessori e Ricambi a richiesta  
List of Accessories & Spare parts on request

Per utensili con codolo cilindrico tipo whistle-notch secondo norma DIN 1835E | 6359HE.  
For tools with whistle-notch cylindrical shank according to DIN 1835E | 6359HE.

AD

G 6.3 15.000 giri/min | G 6.3 15.000 rpm

Max. 3 µm (3 x d)

Vite di bloccaggio | Clamping screw

Vedi pagina 97 | See page 97

Codice d'ordine  
Order Code

STATUS

**BTWN 40**

BTWN 40X6X50	●
BTWN 40X8X50	●
BTWN 40X10X63	●
BTWN 40X12X63	●
BTWN 40X14X63	●
BTWN 40X16X63	●
BTWN 40X18X63	●

SK	d	A	l <sub>1</sub>	D
----	---	---	----------------	---

40	6	50	116	25
40	8	50	116	28
40	10	63	129	35
40	12	63	129	42
40	14	63	129	42
40	16	63	129	48
40	18	63	129	48

La gamma prosegue nella pagina successiva | The range continues on the next page >>



Codice d'ordine Order Code	STATUS	SK	d	A	I <sub>1</sub>	D
<b>BTWN 40</b>						
BTWN 40X20X63	●	40	20	63	129	52
BTWN 40X25X100	●	40	25	100	166	65
BTWN 40X32X100	●	40	32	100	166	72
<b>BTWN 50</b>						
BTWN 50X6X63	●	50	6	63	165	25
BTWN 50X8X63	●	50	8	63	165	28
BTWN 50X10X63	●	50	10	63	165	35
BTWN 50X12X80	●	50	12	80	182	42
BTWN 50X14X80	●	50	14	80	182	42
BTWN 50X16X80	●	50	16	80	182	48
BTWN 50X18X80	●	50	18	80	182	48
BTWN 50X20X80	●	50	20	80	182	52
BTWN 50X25X100	●	50	25	100	202	65
BTWN 50X32X105	●	50	32	105	207	72
BTWN 50X40X120	●	50	40	120	222	80

## Accessori e Ricambi | Accessories & Spare Parts

	Codice Code	Pagina Page
<b>01 VITE DI BLOCCAGGIO   CLAMPING SCREW</b>		
Standard	SWE ..	p. 280
<b>02 TIRANTI - MAS403 BT   PULL STUDS - MAS403 BT</b>		
Con foro di lubrificazione   With bore	TRBTC	p. 266
Senza foro di lubrificazione   Without bore	TRBTS	p. 267



01



02

**BTFI-BTFIB**

**PORTAFRESE FISSI (DIN 6357)  
SHELL END MILL HOLDERS (DIN 6357)**

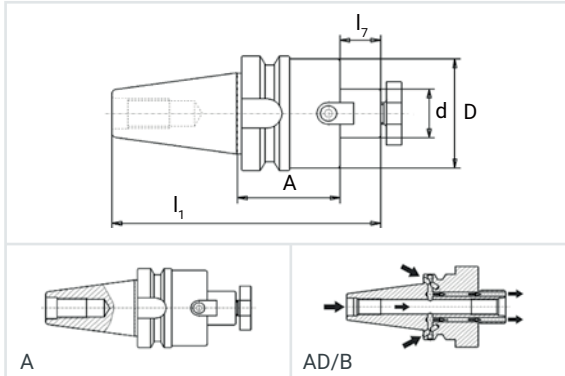

**Dettagli tecnici | Technical details**

Applicazione   Application	Per frese con scanalatura trasversale For end mills with cross groove
Forma   Form	A - AD/B
Grado di bilanciatura   Degree of balancing	-
Run Out	Max. 8 µm
Accessori forniti   Accessories provided	Con due chiavette di trascinamento fisse e vite di bloccaggio DIN 6367 With two fixed drive keys and clamping screw DIN 6367
Elenco Accessori e Ricambi a richiesta List of Accessories & Spare parts on request	Vedi pagina 102   See page 102

Codice d'ordine Order Code	STATUS
-------------------------------	--------

BTFI 40	
BTFI 40X16X45	●
BTFI 40X16X100	●
BTFI 40X22X45	●
BTFI 40X22X100	NEW ●
BTFI 40X27X45	●
BTFI 40X27X100	NEW ●
BTFI 40X32X50	●

SK	d	A	l <sub>1</sub>	l <sub>2</sub>	D	Forma Form
40	16	45	128	17	38	A
40	16	100	183	17	38	A
40	22	45	130	19	48	A
40	22	100	185	19	48	A
40	27	45	132	21	58	A
40	27	100	187	21	58	A
40	32	50	140	24	78	A

La gamma prosegue nella pagina successiva | The range continues on the next page >>

Codice d'ordine Order Code	STATUS	SK	d	A	l <sub>1</sub>	l <sub>2</sub>	D	Forma Form
<b>BTFI 40</b>								
BTFI 40X32X100	NEW ●	40	32	100	190	24	78	A
BTFI 40X40X55	●	40	40	55	148	27	89	A
BTFI 40X40X100	NEW ●	40	40	100	193	27	89	A
<b>BTFI 50</b>								
BTFI 50X22X55	●	50	22	55	176	19	48	A
BTFI 50X22X100	●	50	22	100	221	19	48	A
BTFI 50X27X55	●	50	27	55	178	21	58	A
BTFI 50X27X100	●	50	27	100	223	21	58	A
BTFI 50X32X55	●	50	32	55	181	24	78	A
BTFI 50X32X100	●	50	32	100	226	24	78	A
BTFI 50X32X160	NEW ●	50	32	160	286	24	78	A
BTFI 50X40X55	●	50	40	55	184	27	89	A
BTFI 50X40X100	NEW ●	50	40	100	229	27	89	A
<b>BTFIB 40</b>								
BTFIB 40X16X45	NEW ●	40	16	45	128	17	38	AD/B
BTFIB 40X16X100	NEW ●	40	16	100	183	17	38	AD/B
BTFIB 40X16X160	NEW ●	40	16	160	243	17	40	AD/B
BTFIB 40X22X45	NEW ●	40	22	45	130	19	48	AD/B
BTFIB 40X22X100	NEW ●	40	22	100	185	19	48	AD/B
BTFIB 40X22X160	NEW ●	40	22	160	245	19	48	AD/B
BTFIB 40X27X45	NEW ●	40	27	45	132	21	58	AD/B
BTFIB 40X27X100	NEW ●	40	27	100	187	21	58	AD/B
BTFIB 40X32X50	NEW ●	40	32	50	140	24	78	AD/B
BTFIB 40X32X100	NEW ●	40	32	100	190	24	78	AD/B
BTFIB 40X40X55	NEW ●	40	40	55	148	27	89	AD/B
<b>BTFIB 50</b>								
BTFIB 50X16X100	NEW ●	50	16	100	219	17	38	AD/B
BTFIB 50X16X160	NEW ●	50	16	160	279	17	38	AD/B
BTFIB 50X22X55	NEW ●	50	22	55	176	19	48	AD/B
BTFIB 50X22X100	NEW ●	50	22	100	221	19	48	AD/B
BTFIB 50X27X55	NEW ●	50	27	55	178	21	58	AD/B
BTFIB 50X27X100	NEW ●	50	27	100	223	21	58	AD/B
BTFIB 50X32X55	NEW ●	50	32	55	181	24	78	AD/B
BTFIB 50X32X100	NEW ●	50	32	100	226	24	78	AD/B
BTFIB 50X40X55	NEW ●	50	40	55	184	27	89	AD/B
BTFIB 50X40X100	NEW ●	50	40	100	229	27	89	AD/B
BTFIB 50X60X80	NEW ●	50	60	80	212	40	129	AD/B

**BTAC - BTACB**

**PORTAFRESE COMBINATI (DIN 6358)  
COMBI SHELL END MILL HOLDERS (DIN 6358)**

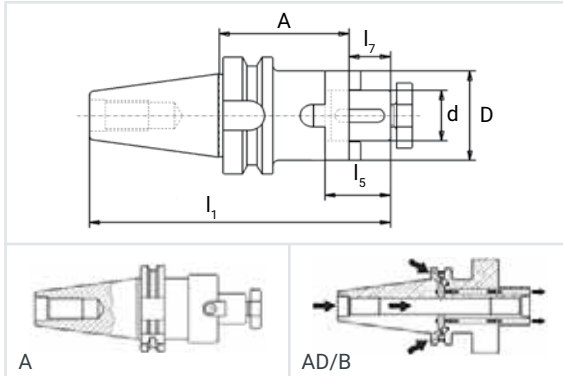

**Dettagli tecnici | Technical details**

Applicazione | Application

Per frese con scanalatura longitudinale o trasversale  
For end mills with longitudinal and cross groove

Forma | Form

A - AD/B

Grado di bilanciatura | Degree of balancing

-

Run Out

Max. 8 µm

Accessori forniti | Accessories provided

Con Vite di bloccaggio DIN 6367, anello di trascinamento DIN 6366 e chiave di trascinamento.  
With clamping screw DIN 6367, drive ring DIN 6366 and feather key.

Elenco Accessori e Ricambi a richiesta  
List of Accessories & Spare parts on request

Vedi pagina 102 | See page 102

Codice d'ordine  
Order Code STATUS

SK	d	A	l <sub>1</sub>	l <sub>5</sub>	l <sub>7</sub>	D	Forma Form		
<b>BTAC 30</b>									
BTAC 30X16X45	●	30	16	45	110	27	17	32	A
BTAC 30X22X47	●	30	22	47	114	31	19	40	A
BTAC 30X27X49	●	30	27	49	118	33	21	48	A
<b>BTAC 40</b>									
BTAC 40X16X55	●	40	16	55	138	27	17	32	A
BTAC 40X16X100	NEW ●	40	16	100	183	27	17	32	A

La gamma prosegue nella pagina successiva | The range continues on the next page >>

Codice d'ordine Order Code	STATUS	SK	d	A	l <sub>1</sub>	l <sub>5</sub>	l <sub>7</sub>	D	Forma Form
<b>BTAC 40</b>									
BTAC 40X16X160	●	40	16	160	243	27	17	32	A
BTAC 40X22X55	●	40	22	55	140	31	19	40	A
BTAC 40X22X100	NEW ●	40	22	100	185	31	19	40	A
BTAC 40X27X55	●	40	27	55	142	33	21	48	A
BTAC 40X27X100	NEW ●	40	27	100	187	33	21	48	A
BTAC 40X32X60	●	40	32	60	150	38	24	58	A
BTAC 40X32X100	NEW ●	40	32	100	190	38	24	58	A
BTAC 40X40X60	●	40	40	60	153	41	27	70	A
BTAC 40X40X100	NEW ●	40	40	100	193	41	27	70	A
<b>BTAC 50</b>									
BTAC 50X16X70	●	50	16	70	189	27	17	32	A
BTAC 50X16X100	NEW ●	50	16	100	219	27	17	32	A
BTAC 50X22X70	●	50	22	70	191	31	19	40	A
BTAC 50X22X100	NEW ●	50	22	100	221	31	19	40	A
BTAC 50X27X70	●	50	27	70	193	33	21	48	A
BTAC 50X27X100	NEW ●	50	27	100	223	33	21	48	A
BTAC 50X32X70	●	50	32	70	196	38	24	58	A
BTAC 50X32X100	NEW ●	50	32	100	226	38	24	58	A
BTAC 50X32X160	●	50	32	160	286	38	24	58	A
BTAC 50X40X70	●	50	40	70	199	41	27	70	A
BTAC 50X40X100	NEW ●	50	40	100	229	41	27	70	A
<b>BTACB 40</b>									
BTACB 40X16X55	NEW ●	40	16	55	138	27	17	32	AD/B
BTACB 40X22X55	NEW ●	40	22	55	140	31	19	40	AD/B
BTACB 40X27X55	NEW ●	40	27	55	142	33	21	48	AD/B
BTACB 40X32X60	NEW ●	40	32	60	150	38	24	58	AD/B
BTACB 40X40X60	NEW ●	40	40	60	153	41	27	70	AD/B
<b>BTACB 50</b>									
BTACB 50X16X70	NEW ●	50	16	70	189	27	17	32	AD/B
BTACB 50X22X70	NEW ●	50	22	70	191	31	19	40	AD/B
BTACB 50X27X70	NEW ●	50	27	70	193	33	21	48	AD/B
BTACB 50X32X70	NEW ●	50	32	70	196	38	24	58	AD/B
BTACB 50X40X70	NEW ●	50	40	70	199	41	27	70	AD/B

Accessori e Ricambi alla pagina successiva | Accessories and Spare Parts on the next page >>

Accessori e Ricambi (BTFI-BTFIB-BTAC-BTACB) | Accessories & Spare Parts (BTFI-BTFIB-BTAC-BTACB)

	Codice Code	Pagina Page
<b>01 ANELLO DI TRASCINAMENTO   DRIVE RING</b>		
Standard	ANTR	p. 286
<b>02 CHIAVE DI BLOCCAGGIO   CLAMPING WRENCH</b>		
Standard	CVCR	p. 279
<b>03 VITE DI BLOCCAGGIO   CLAMPING SCREW</b>		
Standard	VTGR	p. 281
<b>04 TIRANTI - MAS403 BT   PULL STUDS - MAS403 BT</b>		
Con foro di lubrificazione   With bore	TRBTC	p. 266
Senza foro di lubrificazione   Without bore	TRBTS	p. 267
<b>05 PROLUNGHE - (BTFI-BTFIB)   EXTENSIONS - (BTFI-BTFIB)</b>		
Standard	PRFI	p. 212



01



02



03



04



05

## BTAS

### PORTAPUNTE AUTOSERRANTI (STANDARD) DRILL CHUCKS (STANDARD)

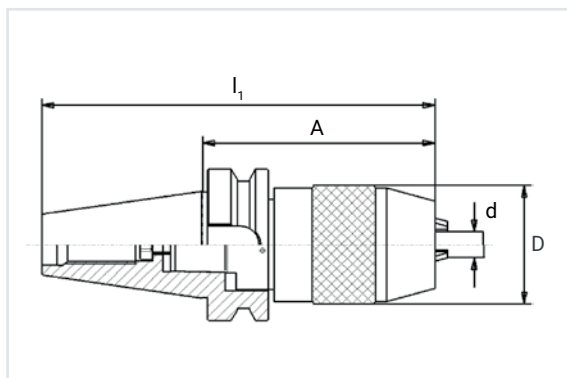

#### Dettagli tecnici | Technical details

Applicazione | Application

Per punte con codolo cilindrico in differenti tolleranze  
For drills with cylindrical shank in different tolerances

Forma | Form

A

Grado di bilanciatura | Degree of balancing

-

Run Out

Max. 50 µm

Accessori forniti | Accessories provided

Chiave | Key

Accessori e Ricambi a richiesta

Accessories & Spare parts on request

Tiranti (vedi pagina 260-261) | Pull Studs (see page 260-261)

Codice d'ordine  
Order Code

STATUS

SK

d

A

I<sub>1</sub>

D

#### BTAS 40

BTAS 40X13 ●

40 13 94 160 50

BTAS 40X16 ●

40 16 97 163 57

#### BTAS 50

BTAS 50X16 ●

50 16 109 211 57

**BTDS-BTDSB**

**PORTAPUNTE AUTOSERRANTI  
(ALTA PRECISIONE)  
DRILL CHUCKS (HIGH PRECISION)**

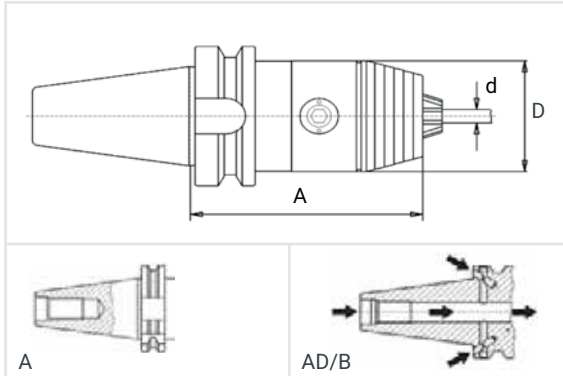

**Dettagli tecnici | Technical details**

Applicazione | Application

Per punte con codolo cilindrico in differenti tolleranze  
For drills with cylindrical shank in different tolerances

Forma | Form

A - AD/B

Grado di bilanciatura | Degree of balancing

-

Run Out

Max. 20 µm

Accessori forniti | Accessories provided

Chiave | Key

Elenco Accessori e Ricambi a richiesta  
List of Accessories & Spare parts on request

Vedi pagina 105 | See page 105

Codice d'ordine Order Code	STATUS	SK	d	A	D	Range	Forma Form
<b>BTDS 30</b>							
BTDS 30X8	●	30	8	74	36	0,3-8	A
BTDS 30X13	●	30	13	96	50	0,5-13	A
<b>BTDS 40</b>							
BTDS 40X8	●	40	8	81	36	0,3-8	A
BTDS 40X13	●	40	13	98	50	0,5-13	A
BTDS 40X16	●	40	16	103	57	2,5-16	A

La gamma prosegue nella pagina successiva | The range continues on the next page >>



# MAS403 - BT [BTDS-BTDSB]

Portapunte Autoserranti (Alta Precisione) | Drill Chucks (High Precision)

Codice d'ordine Order Code	STATUS	SK	d	A	D	Range	Forma Form
<b>BTDS 50</b>							
BTDS 50X13	●	50	13	110	50	0,5-13	A
BTDS 50X16	●	50	16	115	57	2,5-16	A
<b>BTDSB 40</b>							
BTDSB 40X8	NEW ●	40	8	81	36	0,3-8	AD/B
BTDSB 40X13	NEW ●	40	13	98	50	0,5-13	AD/B
BTDSB 40X16	NEW ●	40	16	103	57	2,5-16	AD/B
<b>BTDSB 50</b>							
BTDSB 50X13	NEW ●	50	13	110	50	0,5-13	AD/B
BTDSB 50X16	NEW ●	50	16	115	57	2,5-16	AD/B

## Accessori e Ricambi | Accessories & Spare Parts

	Codice Code	Pagina Page
<b>04 TIRANTI - MAS403 BT   PULL STUDS - MAS403 BT</b>		
Con foro di lubrificazione   With bore	TRBTC	p. 266
Senza foro di lubrificazione   Without bore	TRBTS	p. 267



01

# BTMS

## PORTA MASCHI TAPPING CHUCKS

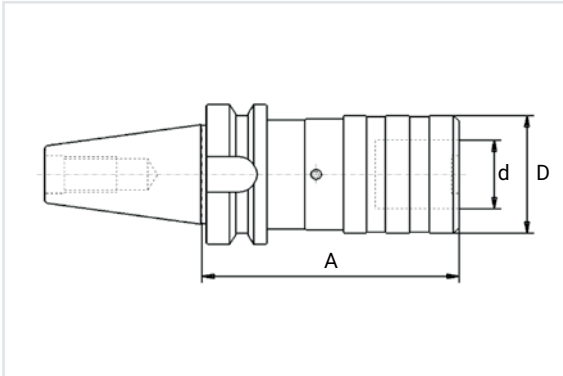

### Dettagli tecnici | Technical details

Applicazione | Application

Per bussole porta maschio a cambio rapido con compensazione assiale  
For quick change tapping chuck with axial compensation

Forma | Form

A

Grado di bilanciatura | Degree of balancing

-

Run Out

-

Accessori forniti | Accessories provided

-

Elenco Accessori e Ricambi a richiesta  
List of Accessories & Spare parts on request

Vedi pagina 107 | See page 107

Codice d'ordine  
Order Code

STATUS

SK	Tipo Type	d	A	D	M
----	--------------	---	---	---	---

#### BTMS 30

BTMS 30X1	●
BTMS 30X2	●

30	1	19	63	38	M3-M12
30	2	31	96	55	M8-M20

#### BTMS 40

BTMS 40X1	●
BTMS 40X2	●

40	1	19	68	38	M3-M12
40	2	31	93	55	M8-M20

La gamma prosegue nella pagina successiva | The range continues on the next page >>

Codice d'ordine Order Code	STATUS	SK	Tipo Type	d	A	D	M
<b>BTMS 50</b>							
BTMS 50X1	●	50	1	19	80	38	M3-M12
BTMS 50X2	●	50	2	31	102	55	M8-M20
BTMS 50X3	●	50	3	48	133	79	M14-M33
BTMS 50X4	NEW ●	50	4	60	147	98	M22-M48

## Accessori e Ricambi | Accessories & Spare Parts

	Codice Code	Pagina Page
<b>01 PINZE CON FRIZIONE   TAPPING COLLETS WITH CLUTCH</b>		
Standard	PZCFR	p. 242
<b>02 PINZE SENZA FRIZIONE   TAPPING COLLETS WITHOUT CLUTCH</b>		
Standard	PZSFR	p. 244



01



02

## BTCM-BTCMB

### ATTACCO CONO MORSE PER PUNTE (DIN 6383) MORSE TAPER FOR DRILLS (DIN 6383)

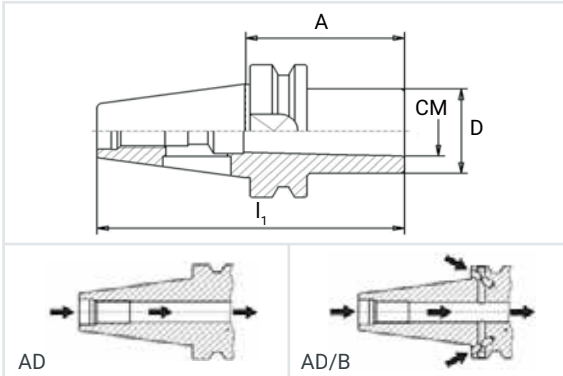

#### Dettagli tecnici | Technical details

Applicazione | Application

Per punte attacco cono morse  
For drills with cono morse shank

Forma | Form

AD - AD/B

Grado di bilanciatura | Degree of balancing

G 6.3 15.000 giri/min | G 6.3 15.000 rpm

Run Out

Max. 10 µm

Accessori forniti | Accessories provided

-

Elenco Accessori e Ricambi a richiesta  
List of Accessories & Spare parts on request

Vedi pagina 109 | See page 109

Codice d'ordine  
Order Code

STATUS

SK CM A l<sub>1</sub> D Forma Form

#### BTCM 30

BTCM 30X1X45	●
BTCM 30X2X60	●
BTCM 30X3X77	●

30	1	45	93	25	AD
30	2	60	108	32	AD
30	3	77	125	40	AD

#### BTCM 40

BTCM 40X1X50	●
BTCM 40X2X50	●

40	1	50	116	25	AD
40	2	50	116	32	AD

La gamma prosegue nella pagina successiva | The range continues on the next page >>

Codice d'ordine Order Code	STATUS	SK	CM	A	I <sub>1</sub>	D	Forma Form
<b>BTCM 40</b>							
BTCM 40X3X70	●	40	3	70	136	40	AD
BTCM 40X4X95	●	40	4	95	161	48	AD
<b>BTCM 50</b>							
BTCM 50X1X45	●	50	1	45	147	25	AD
BTCM 50X2X50	●	50	2	50	152	32	AD
BTCM 50X3X65	●	50	3	65	167	40	AD
BTCM 50X4X95	●	50	4	95	197	48	AD
BTCM 50X5X105	●	50	5	105	207	63	AD
<b>BTCMB 40</b>							
BTCMB 40X1X50	NEW ●	40	1	50	116	25	AD/B
BTCMB 40X2X50	NEW ●	40	2	50	116	32	AD/B
BTCMB 40X3X70	NEW ●	40	3	70	136	40	AD/B
BTCMB 40X4X95	NEW ●	40	4	95	161	48	AD/B

## Accessori e Ricambi | Accessories & Spare Parts

	Codice Code	Pagina Page
<b>01 TIRANTI - MAS403 BT   PULL STUDS - MAS403 BT</b>		
Con foro di lubrificazione   With bore	TRBTC	p. 266
Senza foro di lubrificazione   Without bore	TRBTS	p. 267
<b>02 TENONE DI ESPULSIONE   TANGS TO SCREW IN</b>		
Standard	TEVT	p. 273



01



02

## BTMK

### ATTACCO CONO MORSE PER FRESE (DIN 6364) MORSE TAPER FOR END MILLS (DIN 6364)

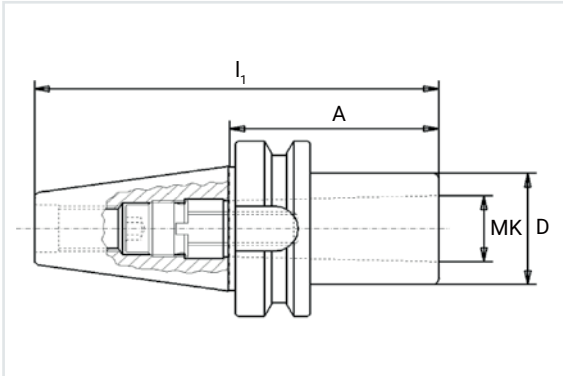

#### Dettagli tecnici | Technical details

Applicazione | Application

Per frese attacco cono morse  
For end mills with cono morse shank

Forma | Form

A

Grado di bilanciatura | Degree of balancing

G 6.3 15.000 giri/min | G 6.3 15.000 rpm

Run Out

Max. 10 µm

Accessori forniti | Accessories provided

Vite di bloccaggio | Clamping screw

Elenco Accessori e Ricambi a richiesta  
List of Accessories & Spare parts on request

Vedi pagina 111 | See page 111

Codice d'ordine  
Order Code

STATUS

SK

MK

A

$l_1$

D

#### BTMK 40

BTMK 40X1X50	●
BTMK 40X2X50	●
BTMK 40X3X70	●
BTMK 40X4X95	●

40	1	50	116	25
40	2	50	116	32
40	3	70	136	40
40	4	95	161	48

La gamma prosegue nella pagina successiva | The range continues on the next page >>

Codice d'ordine Order Code	STATUS	SK	MK	A	I <sub>1</sub>	D
<b>BTMK 50</b>						
BTMK 50X1X45	●	50	1	45	147	25
BTMK 50X2X60	●	50	2	60	162	32
BTMK 50X3X65	●	50	3	65	167	40
BTMK 50X4X90	●	50	4	90	192	48
BTMK 50X5X110	●	50	5	110	212	63

## Accessori e Ricambi | Accessories & Spare Parts

	Codice Code	Pagina Page
<b>01 TIRANTI - MAS403 BT   PULL STUDS - MAS403 BT</b>		
Con foro di lubrificazione   With bore	TRBTC	p. 266
Senza foro di lubrificazione   Without bore	TRBTS	p. 267
<b>02 TIRANTI PROLUNGATI - MAS403 BT   EXTENDED PULL STUDS - MAS403 BT</b>		
Con foro di lubrificazione   With bore	TRBTXL	p. 268



01



02

**BTD**

**ATTACCO CONICO (DIN 238)  
TAPER SHAFTS (DIN 238)**

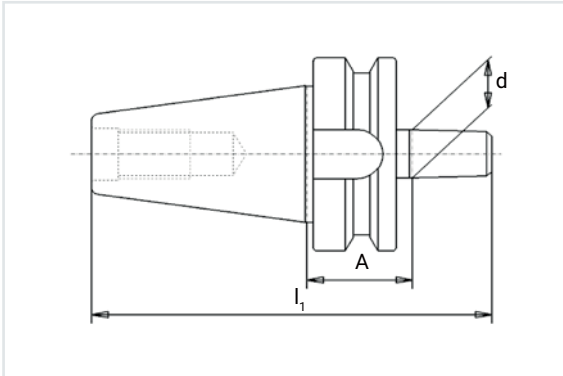

**Dettagli tecnici | Technical details**

Applicazione   Application	Per mandrini DIN 238 For toolholders DIN 238
Forma   Form	A
Grado di bilanciatura   Degree of balancing	-
Run Out	-
Accessori forniti   Accessories provided	Senza mandrino autoserrante   Without drill chuck head
Elenco Accessori e Ricambi a richiesta List of Accessories & Spare parts on request	Vedi pagina 113   See page 113

Codice d'ordine Order Code	STATUS
-------------------------------	--------

**BTD 30**

BTD 30X12	●
BTD 30X16	●

**BTD 40**

BTD 40X12	●
BTD 40X16	●

SK	d	A	l <sub>1</sub>
30	12	25	92
30	16	27	99
40	12	30	112
40	16	32	121

La gamma prosegue nella pagina successiva | The range continues on the next page >>



Codice d'ordine Order Code	STATUS	SK	d	A	l <sub>1</sub>
<b>BTD 40</b>					
BTD 40X18	●	40	18	32	129
<b>BTD 50</b>					
BTD 50X16	●	50	16	43	169
BTD 50X18	●	50	18	43	177

## Accessori e Ricambi | Accessories & Spare Parts

	Codice Code	Pagina Page
<b>01 TIRANTI - MAS403 BT   PULL STUDS - MAS403 BT</b>		
Con foro di lubrificazione   With bore	TRBTC	p. 266
Senza foro di lubrificazione   Without bore	TRBTS	p. 267



01

**BTMR**

**MANDRINI DI RIDUZIONE  
REDUCTION ARBOR**

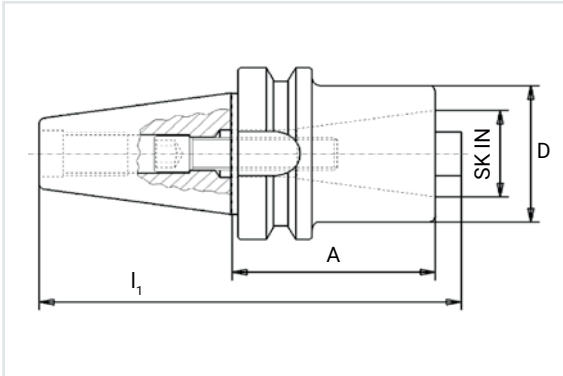

**Dettagli tecnici | Technical details**

Applicazione | Application

Per riduzione cono ad elevata rastrematura SK  
For SK high taper cone reduction

Forma | Form

A

Accessori forniti | Accessories provided

Vite di bloccaggio | Clamping screw

Accessori e Ricambi a richiesta  
Accessories & Spare parts on request

Tiranti (vedi pagina 260-261) | Pull Studs (see page 260-261)

Codice d'ordine Order Code	STATUS	SK Out/In	A	l <sub>1</sub>	D
<b>BTMR 40</b>					
BTMR 40X30	NEW ●	40 X 30	60	134	50
BTMR 40X40	NEW ●	40 X 40	100	176	70
<b>BTMR 50</b>					
BTMR 50X40	NEW ●	50 X 40	70	193	70
BTMR 50X50	NEW ●	50 X 50	120	236	97

In fase d'ordine specificare se si desidera ridurre o prolungare un cono DIN2080, DIN69871 o MAS BT.  
When ordering please give information wether you want to reduce or extend a taper DIN2080, DIN69871 or MAS BT.

## BTSL

### SEMI LAVORATO BLANK BARS

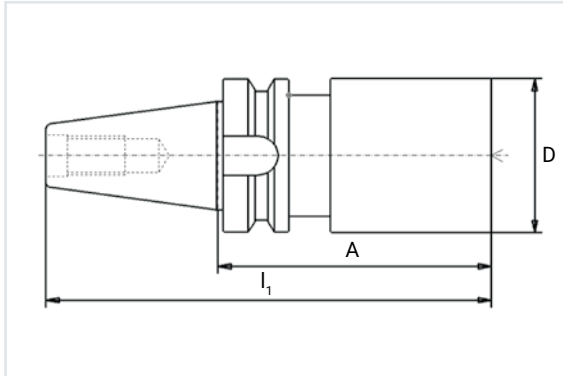

#### Dettagli tecnici | Technical details

Applicazione   Application	Per la produzione di mandrini speciali For the production of special tool holders
Forma   Form	A
Accessori forniti   Accessories provided	-
Accessori e Ricambi a richiesta Accessories & Spare parts on request	Tiranti (vedi pagina 260-261)   Pull Studs (see page 260-261)

Codice d'ordine Order Code	STATUS	SK	A	l <sub>1</sub>	D
<b>BTSL 40</b>					
BTSL 40X63X250	NEW ●	40	250	316	63
<b>BTSL 50</b>					
BTSL 50X97X315	NEW ●	50	315	417	97



p. 118-120

## HSKCL

Calettamento a Caldo  
"standard"  
Shrink Fit Holders  
"Standard"



NEW

p. 121-122

## HSKCLS

Calettamento a Caldo  
"Slim"  
Shrink Fit Holders  
"Slim"



p. 123-124

## HSKID

Serraggio Idraulico  
Hydraulic Chucks



NEW

p. 125-126

## HSKFS

Forte Serraggio  
Power Milling Chucks



NEW

p. 127-128

## HSKTF

Porta Testine Filetate  
(Tipo Conico)  
Screwed Milling Cutters  
(Tapered Type)



NEW

p. 129-130

## HSKTFC

Porta Testine Filetate  
(Tipo Cilindrico)  
Screwed Milling Cutters  
(Cylindrical Type)



p. 131-133

## HSKER

Portapinze ER  
(DIN 6499)  
Collet Chucks ER  
(DIN 6499)



NEW

p. 134-135

## HSKERM

Portapinze ER MINI  
(DIN 6499)  
Collet Chucks ER MINI  
(DIN 6499)



p. 136-137

## HSKWE

Attacco Weldon  
Weldon Holders



p. 138-139

## HSKWEG

Attacco Weldon con  
Canalini di Lubrificazione  
Weldon Holders with  
Coolant Grooves



p. 140-141

## HSKWN

Attacco Whistle Notch  
Whistle-Notch Holders



p. 142-144

## HSKFI

Portafrese Fissi  
(DIN 6357)  
Shell End Mill Holders  
(DIN 6357)



# HSK - DIN 69893

Indice di sezione | Section Index

HSK - DIN 69893



NEW

p. 145-147

## HSKAC

Portafrese Combinati  
(DIN 6358)  
Combi Shell End Mill Holders  
(DIN 6358)



p. 148-149

## HSKDS

Portapunte Autoserranti  
Alta Precisione  
High Precision  
Drill Chucks



p. 150-151

## HSKMS

Porta Maschi  
Tapping Chucks



p. 152-153

## HSKCM

Attacco Cono Morse  
per Punta (DIN 6383)  
Morse Taper  
for Drills (DIN 6383)



p. 154-155

## HSKMK

Attacco Cono Morse  
per Frese (DIN 6364)  
Morse Taper  
for End Mills (DIN 6364)



NEW

p. 156

## HSKSL

Semi Lavorato  
Blank Bars



NEW

p. 157

## HSKCK

Barre di Controllo  
Test Arbors

# HSKCL

## CALETTAMENTO A CALDO "STANDARD" SHRINK FIT HOLDERS "STANDARD"

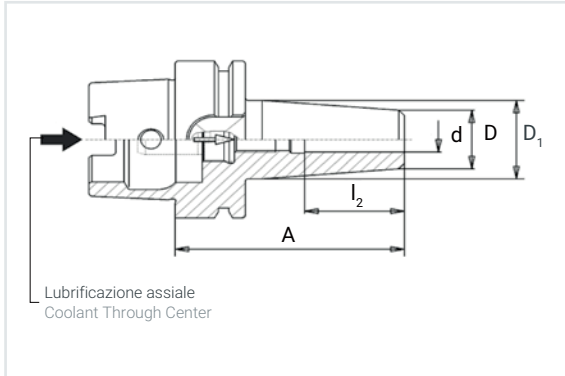

### Dettagli tecnici | Technical details

Applicazione   Application	Per utensili con codolo cilindrico in tolleranza h6 For tools with cylindrical shank with h6 tolerance
Forma   Form	HSK A
Grado di bilanciatura   Degree of balancing	G 2.5 20.000 giri/min   G 2.5 20.000 rpm
Run Out	Max. 3 µm
Accessori forniti   Accessories provided	-
Elenco Accessori e Ricambi a richiesta List of Accessories & Spare parts on request	Vedi pagina 120   See page 120

Codice d'ordine Order Code	STATUS
-------------------------------	--------

HSKCL 63	
HSKCL 63X3X80	NEW ●
HSKCL 63X3X120	NEW ●
HSKCL 63X3X160	NEW ●
HSKCL 63X4X80	NEW ●
HSKCL 63X4X120	NEW ●
HSKCL 63X4X160	NEW ●
HSKCL 63X5X80	NEW ●

SK	d	A	I <sub>2</sub>	D	D <sub>1</sub>
63	3	80	15	10	20
63	3	120	15	10	20
63	3	160	15	10	20
63	4	80	15	15	22
63	4	120	15	15	22
63	4	160	15	15	22
63	5	80	20	15	22

La gamma prosegue nella pagina successiva | The range continues on the next page >>

Codice d'ordine Order Code	STATUS	SK	d	A	I <sub>2</sub>	D	D <sub>1</sub>
<b>HSKCL 63</b>							
HSKCL 63X5X120	NEW ●	63	5	120	20	15	22
HSKCL 63X5X160	NEW ●	63	5	160	20	15	22
HSKCL 63X6X80	●	63	6	80	36	21	27
HSKCL 63X6X120	●	63	6	120	36	20	27
HSKCL 63X6X160	NEW ●	63	6	160	36	21	27
HSKCL 63X8X80	●	63	8	80	36	21	27
HSKCL 63X8X120	NEW ●	63	8	120	36	20	27
HSKCL 63X8X160	●	63	8	160	36	21	27
HSKCL 63X10X85	●	63	10	85	42	24	31
HSKCL 63X10X120	NEW ●	63	10	120	41	24	31
HSKCL 63X10X160	●	63	10	160	42	24	31
HSKCL 63X12X90	●	63	12	90	47	24	31
HSKCL 63X12X120	●	63	12	120	47	24	31
HSKCL 63X12X160	●	63	12	160	47	24	31
HSKCL 63X14X90	●	63	14	90	47	27	34
HSKCL 63X14X160	●	63	14	160	47	27	34
HSKCL 63X16X90	●	63	16	90	50	27	34
HSKCL 63X16X120	NEW ●	63	16	120	50	27	34
HSKCL 63X16X160	●	63	16	160	50	27	34
HSKCL 63X18X95	●	63	18	95	50	33	40
HSKCL 63X18X160	●	63	18	160	50	33	40
HSKCL 63X20X100	●	63	20	100	52	33	40
HSKCL 63X20X120	NEW ●	63	20	120	52	33	40
HSKCL 63X20X160	●	63	20	160	52	33	40
HSKCL 63X25X115	●	63	25	115	58	44	53
HSKCL 63X25X160	●	63	25	160	58	44	53
HSKCL 63X32X120	NEW ●	63	32	120	62	44	53
HSKCL 63X32X160	NEW ●	63	32	160	62	44	53
<b>HSKCL 100</b>							
HSKCL 100X6X85	●	100	6	85	36	20	27
HSKCL 100X6X120	NEW ●	100	6	120	36	20	27
HSKCL 100X6X160	●	100	6	160	36	20	27
HSKCL 100X8X85	●	100	8	85	36	20	27
HSKCL 100X8X120	NEW ●	100	8	120	36	20	27
HSKCL 100X8X160	●	100	8	160	36	20	27
HSKCL 100X10X90	●	100	10	90	42	24	31
HSKCL 100X10X120	NEW ●	100	10	120	42	24	31
HSKCL 100X10X160	●	100	10	160	42	24	31
HSKCL 100X12X95	●	100	12	95	47	24	31
HSKCL 100X12X120	NEW ●	100	12	120	47	24	31
HSKCL 100X12X160	●	100	12	160	47	24	31

La gamma prosegue nella pagina successiva | The range continues on the next page >>

Codice d'ordine Order Code	STATUS	SK	d	A	l <sub>2</sub>	D	D <sub>1</sub>
<b>HSKCL 100</b>							
HSKCL 100X14X95	●	100	14	95	47	27	34
HSKCL 100X14X160	●	100	14	160	47	27	34
HSKCL 100X16X100	●	100	16	100	50	27	34
HSKCL 100X16X120	NEW ●	100	16	120	50	27	34
HSKCL 100X16X160	●	100	16	160	50	27	34
HSKCL 100X18X100	●	100	18	100	50	33	40
HSKCL 100X18X160	●	100	18	160	50	33	40
HSKCL 100X20X105	●	100	20	105	52	33	40
HSKCL 100X20X120	NEW ●	100	20	120	52	33	40
HSKCL 100X20X160	●	100	20	160	52	33	40
HSKCL 100X25X115	●	100	25	115	58	44	53
HSKCL 100X25X160	●	100	25	160	58	44	53
HSKCL 100X32X120	NEW ●	100	32	120	62	44	53
HSKCL 100X32X160	NEW ●	100	32	160	62	44	53

Accessori e Ricambi | Accessories & Spare Parts

	Codice Code	Pagina Page
<b>01</b> PROLUNGHE PER CALETTAMENTO A CALDO   SHRINK FIT EXTENSIONS		
Standard	PRCL	p. 200
<b>02</b> RACCORDO PER REFRIGERANTE   COOLANT TUBE		
Standard	HSKLB	p. 287
<b>03</b> CHIAVE PER RACCORDO REFRIGERANTE   COOLANT TUBE WRENCH		
Standard	CVLB	p. 276

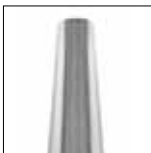

01



02



03



## HSKCLS

### CALETTAMENTO A CALDO "SLIM" SHRINK FIT HOLDERS "SLIM"

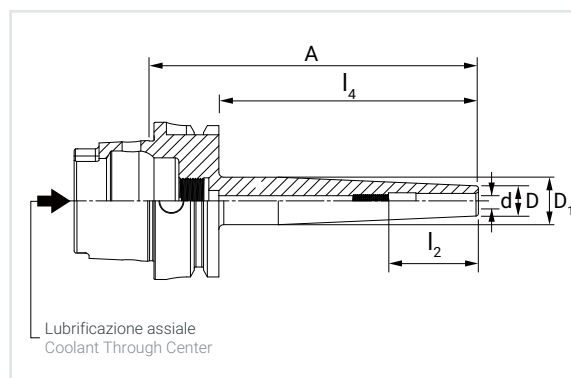

HSK - DIN 69893

#### Dettagli tecnici | Technical details

Applicazione | Application

Per utensili con codolo cilindrico in tolleranza h6  
For tools with cylindrical shank with h6 tolerance

Forma | Form

HSK A

Grado di bilanciatura | Degree of balancing

G 2.5 25.000 giri/min | G 2.5 25.000 rpm

Run Out

Max. 3 µm

Accessori forniti | Accessories provided

-

Elenco Accessori e Ricambi a richiesta  
List of Accessories & Spare parts on request

Vedi pagina 122 | See page 122

Codice d'ordine  
Order Code

STATUS

#### HSKCLS 63

HSKCLS 63X4X80	NEW ●
HSKCLS 63X4X120	NEW ●
HSKCLS 63X6X80	NEW ●
HSKCLS 63X6X130	NEW ●
HSKCLS 63X6X160	NEW ●
HSKCLS 63X8X80	NEW ●
HSKCLS 63X8X130	NEW ●

SK	d	A	l <sub>2</sub>	l <sub>4</sub>	D	D <sub>1</sub>
63	4	80	36	54	10	15
63	4	120	36	94	10	20
63	6	80	36	54	12	16
63	6	130	36	104	12	19
63	6	160	36	134	12	19
63	8	80	36	54	14	18
63	8	130	36	104	14	19

La gamma prosegue nella pagina successiva | The range continues on the next page >>

Codice d'ordine Order Code	STATUS	SK	d	A	I <sub>2</sub>	I <sub>4</sub>	D	D <sub>1</sub>
<b>HSKCLS 63</b>								
HSKCLS 63X8X160	NEW ●	63	8	160	36	134	14	21
HSKCLS 63X10X85	NEW ●	63	10	85	43	59	16	20
HSKCLS 63X10X130	NEW ●	63	10	130	43	104	16	23
HSKCLS 63X10X160	NEW ●	63	10	160	43	134	16	23
HSKCLS 63X12X90	NEW ●	63	12	90	46	64	18	23
HSKCLS 63X12X130	NEW ●	63	12	130	46	104	18	25
HSKCLS 63X12X160	NEW ●	63	12	160	46	134	18	25
HSKCLS 63X14X90	NEW ●	63	14	90	49	64	20	25
HSKCLS 63X14X130	NEW ●	63	14	130	49	104	20	27
HSKCLS 63X14X160	NEW ●	63	14	160	49	134	20	27
HSKCLS 63X16X95	NEW ●	63	16	95	49	69	24	29
HSKCLS 63X16X130	NEW ●	63	16	130	49	104	24	31
HSKCLS 63X16X160	NEW ●	63	16	160	49	134	24	31
HSKCLS 63X18X95	NEW ●	63	18	95	49	69	26	30
HSKCLS 63X18X130	NEW ●	63	18	130	49	104	26	31
HSKCLS 63X18X160	NEW ●	63	18	160	49	134	26	31
HSKCLS 63X20X100	NEW ●	63	20	100	49	74	28	34
HSKCLS 63X20X130	NEW ●	63	20	130	49	104	28	35
HSKCLS 63X20X160	NEW ●	63	20	160	49	134	28	35

Accessori e Ricambi | Accessories & Spare Parts

	Codice Code	Pagina Page
<b>01 RACCORDO PER REFRIGERANTE   COOLANT TUBE</b>		
Standard	HSKLB	p. 287
<b>02 CHIAVE PER RACCORDO REFRIGERANTE   COOLANT TUBE WRENCH</b>		
Standard	CVLB	p. 276



01



02

## HSKID

### SERRAGGIO IDRAULICO HYDRAULIC CHUCKS

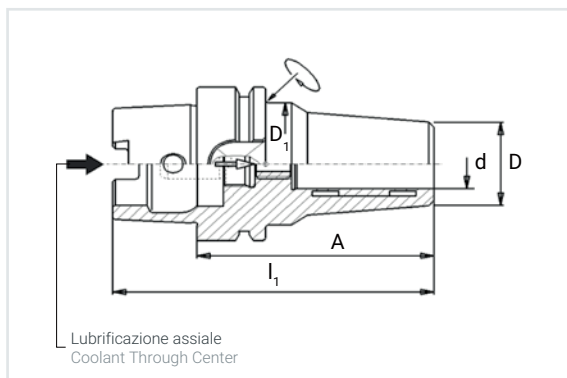

HSK - DIN 69893

#### Dettagli tecnici | Technical details

Applicazione | Application

Per utensili con codolo cilindrico secondo norma DIN 6535 HA-HB, in tolleranza h6.  
For tools with cylindrical shank according to DIN 6535 HA-HB, with h6 tolerance.

Forma | Form

HSK A

Grado di bilanciatura | Degree of balancing

G 2.5 20.000 giri/min | G 2.5 20.000 rpm

Run Out

Max. 3 µm

Accessori forniti | Accessories provided

Chiave | Wrench

Elenco Accessori e Ricambi a richiesta  
List of Accessories & Spare parts on request

Vedi pagina 124 | See page 124

Codice d'ordine  
Order Code STATUS

SK	d	A	l <sub>1</sub>	D	D <sub>1</sub>
63	12	85	117	32	50
63	16	90	122	38	50
63	20	90	122	42	50
63	25	120	152	57	53
63	32	125	157	63	59

#### HSKID 63

HSKID 63X12	●
HSKID 63X16	●
HSKID 63X20	●
HSKID 63X25	●
HSKID 63X32	●

La gamma prosegue nella pagina successiva | The range continues on the next page >>

Codice d'ordine Order Code	STATUS	SK	d	A	I <sub>1</sub>	D	D <sub>1</sub>
<b>HSKID 100</b>							
HSKID 100X20	●	100	20	105	155	42	50
HSKID 100X25	●	100	25	115	165	63	57
HSKID 100X32	●	100	32	120	170	67	63
<b>HSKIDE 63</b> (Versione corta, idonea alle lavorazioni di sgrossatura pesante in fresatura   Short version, suitable for heavy roughing operations in milling)							
HSKIDE 63X20	●	63	20	80	112	33	57

Accessori e Ricambi | Accessories & Spare Parts

	Codice Code	Pagina Page
<b>01 BUSSOLE DI RIDUZIONE   REDUCTION SLEEVE</b>		
Standard	BSID	p. 248
<b>02 RACCORDO PER REFRIGERANTE   COOLANT TUBE</b>		
Standard	HSKLB	p. 287
<b>03 CHIAVE PER RACCORDO REFRIGERANTE   COOLANT TUBE WRENCH</b>		
Standard	CVLB	p. 276
<b>04 PROLUNGHE PER CALETTAMENTO A CALDO   SHRINK FIT EXTENSIONS</b>		
Standard	PRCL	p. 200



01



02



03

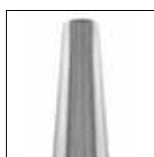

04

## HSKFS

### FORTE SERRAGGIO POWER MILLING CHUCKS

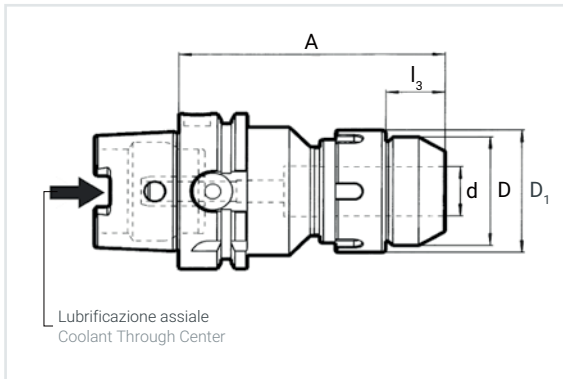

HSK - DIN 69893

#### Dettagli tecnici | Technical details

Applicazione | Application

Forma | Form

Grado di bilanciatura | Degree of balancing

Run Out

Accessori forniti | Accessories provided

Elenco Accessori e Ricambi a richiesta  
List of Accessories & Spare parts on request

Per utensili con codolo cilindrico in differenti tolleranze  
For tools with cylindrical shank in different tolerances

HSK A

G 2.5 20.000 giri/min | G 2.5 20.000 rpm

Max. 4 µm (3 x d)

Chiave | Wrench

Vedi pagina 126 | See page 126

Codice d'ordine  
Order Code

STATUS

#### HSKFS 63

HSKFS 63X20X95	■
HSKFS 63X20X100	NEW ●
HSKFS 63X20X150	NEW ●
HSKFS 63X32X113	NEW ●
HSKFS 63X32X150	NEW ●

SK	d	A	l <sub>3</sub>	D	D <sub>1</sub>
63	20	95	23	46	49
63	20	100	23	46	49
63	20	150	23	46	49
63	32	113	33	67	68
63	32	150	33	67	68

■ Fino ad esaurimento scorte | Till stocks last

Forza e coppia di serraggio | Tightening force and torque

Diametro utensile Tool diameter	Coppia di serraggio massima Maximum tightening torque	Forza di serraggio Clamping force
6	60 Nm	150 Nm
8	60 Nm	180 Nm
10	80 Nm	320 Nm
12	80 Nm	380 Nm
16	100 Nm	400 Nm
20	100 Nm	520 Nm
25	150 Nm	550 Nm
32	150 Nm	800 Nm

Esempio: Il mandrino deve essere bloccato tramite una chiave dinamometrica con coppia di serraggio massima di 60 Nm per raggiungere una forza di serraggio sul codolo alloggiato di 150 Nm.

Example: you should clamp the chuck with a tightening-torque-wrench with the maximum tightening torque of 60 Nm (maximum), to reach a clamping force on the clamped shaft of 150 Nm.

Accessori e Ricambi | Accessories & Spare Parts

	Codice Code	Pagina Page
<b>01 BUSSOLE DI RIDUZIONE   REDUCTION SLEEVE</b>		
Standard	BSFS	p. 246
<b>02 RACCORDO PER REFRIGERANTE   COOLANT TUBE</b>		
Standard	HSKLB	p. 287
<b>03 CHIAVE PER RACCORDO REFRIGERANTE   COOLANT TUBE WRENCH</b>		
Standard	CVLB	p. 276



01



02



03

## HSKTF

### PORTA TESTINE FILETTATE (TIPO CONICO) SCREWED MILLING CUTTERS (TAPERED TYPE)

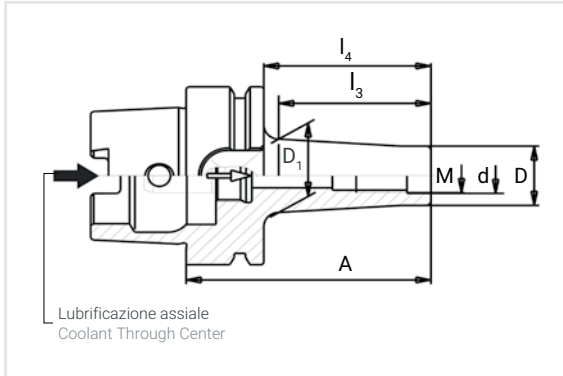

HSK - DIN 69893

#### Dettagli tecnici | Technical details

Applicazione | Application

Per frese con attacco filettato  
For end mills with threaded shank

Forma | Form

HSK A

Grado di bilanciatura | Degree of balancing

G 6.3 15.000 giri/min | G 6.3 15.000 rpm

Run Out

-

Accessori forniti | Accessories provided

-

Elenco Accessori e Ricambi a richiesta  
List of Accessories & Spare parts on request

Vedi pagina 128 | See page 128

Codice d'ordine  
Order Code

STATUS

SK	d	A	M	I <sub>3</sub>	I <sub>4</sub>	D	D <sub>1</sub>
----	---	---	---	----------------	----------------	---	----------------

#### HSKTF 63

HSKTF 63XM6X51	NEW ●
HSKTF 63XM8X51	NEW ●
HSKTF 63XM8X76	NEW ●
HSKTF 63XM8X101	NEW ●
HSKTF 63XM10X51	NEW ●
HSKTF 63XM10X76	NEW ●
HSKTF 63XM10X126	NEW ●

63	6,5	51	M6	23	25	10	13
63	8,5	51	M8	23	25	13	15
63	8,5	76	M8	47	50	13	23
63	8,5	101	M8	97	75	13	23
63	10,5	51	M10	23	25	18	20
63	10,5	76	M10	47	50	18	23
63	10,5	126	M10	97	100	18	32

La gamma prosegue nella pagina successiva | The range continues on the next page >>

Codice d'ordine Order Code	STATUS	SK	d	A	M	l <sub>3</sub>	l <sub>4</sub>	D	D <sub>1</sub>
<b>HSKTF 63</b>									
HSKTF 63XM10X176	NEW ●	63	10,5	176	M10	147	150	18	37
HSKTF 63XM12X51	NEW ●	63	12,5	51	M12	23	25	21	24
HSKTF 63XM12X76	NEW ●	63	12,5	76	M12	47	50	21	24
HSKTF 63XM12X101	NEW ●	63	12,5	101	M12	72	75	21	31
HSKTF 63XM12X126	NEW ●	63	12,5	126	M12	97	100	21	33
HSKTF 63XM12X176	NEW ●	63	12,5	176	M12	147	150	21	40
HSKTF 63XM16X51	NEW ●	63	17	51	M16	22	25	29	29
HSKTF 63XM16X76	NEW ●	63	17	76	M16	47	50	29	34
HSKTF 63XM16X101	NEW ●	63	17	101	M16	72	75	29	34
HSKTF 63XM16X126	NEW ●	63	17	126	M16	97	100	29	36
HSKTF 63XM16X176	NEW ●	63	17	176	M16	147	150	29	43
<b>HSKTF 100</b>									
HSKTF 100XM10X79	NEW ●	100	10,5	79	M10	46	50	18	23
HSKTF 100XM12X79	NEW ●	100	12,5	79	M12	46	50	21	24
HSKTF 100XM12X129	NEW ●	100	12,5	129	M12	96	100	21	33
HSKTF 100XM16X79	NEW ●	100	17	79	M16	46	50	29	34
HSKTF 100XM16X129	NEW ●	100	17	129	M16	96	100	29	40
HSKTF 100XM16X179	NEW ●	100	17	179	M16	146	150	29	42,5

Accessori e Ricambi | Accessories & Spare Parts

	Codice Code	Pagina Page
<b>01</b> PROLUNGHE PER PORTA TESTINE FILETTATE   EXTENSIONS FOR SCREWED MILLING CUTTERS		
Standard	PRTF	p. 210
<b>02</b> RIDUZIONI PER PORTA TESTINE FILETTATE   REDUCTIONS FOR SCREWED MILLING CUTTERS		
Standard	RTF	p. 283
<b>03</b> RACCORDO PER REFRIGERANTE   COOLANT TUBE		
Standard	HSKLB	p. 287
<b>04</b> CHIAVE PER RACCORDO REFRIGERANTE   COOLANT TUBE WRENCH		
Standard	CVLB	p. 276





## HSKTFC

### PORTA TESTINE FILETTATE (TIPO CILINDRICO) SCREWED MILLING CUTTERS (CYLINDRICAL TYPE)

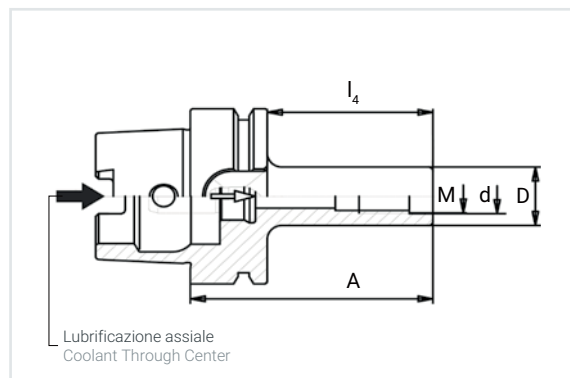

HSK - DIN 69893

#### Dettagli tecnici | Technical details

Applicazione   Application	Per frese con attacco filettato For end mills with threaded shank
Forma   Form	HSK A
Grado di bilanciatura   Degree of balancing	G 6.3 15.000 giri/min   G 6.3 15.000 rpm
Run Out	-
Accessori forniti   Accessories provided	-
Elenco Accessori e Ricambi a richiesta List of Accessories & Spare parts on request	Vedi pagina 130   See page 130

Codice d'ordine Order Code	STATUS
-------------------------------	--------

#### HSKTFC 63

HSKTFC 63XM10X126	NEW ●
HSKTFC 63XM10X176	NEW ●
HSKTFC 63XM12X76	NEW ●
HSKTFC 63XM12X101	NEW ●
HSKTFC 63XM12X126	NEW ●
HSKTFC 63XM12X176	NEW ●
HSKTFC 63XM16X76	NEW ●

SK	d	A	M	I <sub>4</sub>	D
63	10,5	126	M10	100	18
63	10,5	176	M10	150	18
63	12,5	76	M12	50	21
63	12,5	101	M12	75	21
63	12,5	126	M12	100	21
63	12,5	176	M12	150	21
63	17	76	M16	50	29

La gamma prosegue nella pagina successiva | The range continues on the next page >>

Codice d'ordine Order Code	STATUS	SK	d	A	M	I <sub>4</sub>	D
<b>HSKTFC 63</b>							
HSKTFC 63XM16X101	NEW ●	63	17	101	M16	75	29
HSKTFC 63XM16X126	NEW ●	63	17	126	M16	100	29
HSKTFC 63XM16X176	NEW ●	63	17	176	M16	150	29

Accessori e Ricambi | Accessories & Spare Parts

	Codice Code	Pagina Page
<b>01</b> PROLUNGHE PER PORTA TESTINE FILETTATE   EXTENSIONS FOR SCREWED MILLING CUTTERS		
Standard	PRTF	p. 210
<b>02</b> RIDUZIONI PER PORTA TESTINE FILETTATE   REDUCTIONS FOR SCREWED MILLING CUTTERS		
Standard	RTF	p. 283
<b>03</b> RACCORDO PER REFRIGERANTE   COOLANT TUBE		
Standard	HSKLB	p. 287
<b>04</b> CHIAVE PER RACCORDO REFRIGERANTE   COOLANT TUBE WRENCH		
Standard	CVLB	p. 276



01



02



03



04

## HSKER

### PORTAPINZE ER (DIN 6499) COLLET CHUCKS ER (DIN 6499)

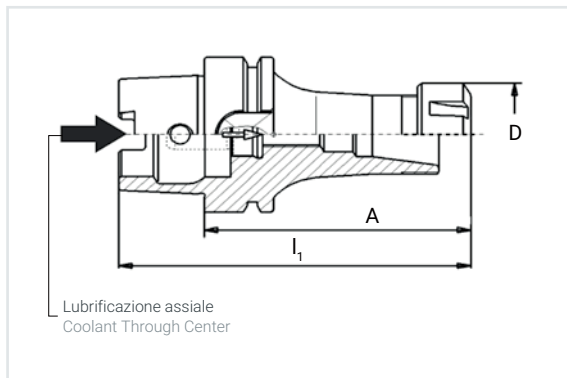

HSK - DIN 69893

#### Dettagli tecnici | Technical details

Applicazione   Application	Per utensili con codolo cilindrico in differenti tolleranze For tools with cylindrical shank in different tolerances
Forma   Form	HSK A
Grado di bilanciatura   Degree of balancing	G 6.3 20.000 giri/min   G 6.3 20.000 rpm
Run Out	Max. 5 µm
Accessori forniti   Accessories provided	Ghiera di bloccaggio standard   Standard clamp nut
Elenco Accessori e Ricambi a richiesta List of Accessories & Spare parts on request	Vedi pagina 133   See page 133

Codice d'ordine Order Code	STATUS
-------------------------------	--------

HSKER 40	
HSKER 40X16X80	NEW ●
HSKER 40X25X80	NEW ●
HSKER 40X32X100	NEW ●

HSKER 50	
HSKER 50X16X100	NEW ●
HSKER 50X25X100	NEW ●

SK	ER	A	I <sub>1</sub>	D
40	16	80	100	28
40	25	80	100	42
40	32	100	120	50
50	16	100	125	28
50	25	100	125	42

La gamma prosegue nella pagina successiva | The range continues on the next page >>

Codice d'ordine Order Code	STATUS	SK	ER	A	I <sub>1</sub>	D
<b>HSKER 50</b>						
HSKER 50X32X100	NEW ●	50	32	100	125	50
<b>HSKER 63</b>						
HSKER 63X16X100	●	63	16	100	132	32
HSKER 63X16X160	●	63	16	160	192	32
HSKER 63X25X100	●	63	25	100	132	42
HSKER 63X25X160	●	63	25	160	192	42
HSKER 63X32X100	●	63	32	100	132	50
HSKER 63X32X160	●	63	32	160	192	50
HSKER 63X40X120	●	63	40	120	152	63
HSKER 63X40X160	●	63	40	160	192	63
<b>HSKER 100</b>						
HSKER 100X16X100	NEW ●	100	16	100	150	32
HSKER 100X16X160	NEW ●	100	16	160	210	32
HSKER 100X25X100	NEW ●	100	25	100	150	42
HSKER 100X25X160	NEW ●	100	25	160	210	42
HSKER 100X32X100	●	100	32	100	150	50
HSKER 100X32X160	●	100	32	160	210	50
HSKER 100X40X120	●	100	40	120	170	63
HSKER 100X40X160	●	100	40	160	210	63

## Accessori e Ricambi | Accessories & Spare Parts

	Codice Code	Pagina Page
<b>01 PINZE ER   ER COLLETS</b>		
Standard	PZER	p. 216
Ultra precise   High precision	ERUP	p. 223
Vulcanizzate   Rubber sealed collets	ERVU	p. 229
Con quadro interno   With internal square	PZSQ	p. 233
A tenuta con fori di lubrificazione   Externally cooled collets	PZERJ	p. 236
<b>02 GHIERA DI BLOCCAGGIO ER   ER CLAMP NUT</b>		
Standard	GRERB	p. 256
Bilanciata   Balanced	GRERC	p. 256
Per forte serraggio   For high clamping power	GRERD	p. 257
Con anello di tenuta   With sealing disk	GRERE	p. 257
Con anello di tenuta a step di 0.5 mm   With sealing disk in 0.5 mm steps	GRERF	p. 257
<b>03 CHIAVE DI BLOCCAGGIO ER   ER WRENCH CLAMP</b>		
Standard	CVER	p. 277
<b>04 PROLUNGHE CILINDRICHE PER PORTA PINZE ER   CYLINDRICAL EXTENSIONS FOR ER COLLET CHUCKS</b>		
Standard	PGCL	p. 202
<b>05 RACCORDO PER REFRIGERANTE   COOLANT TUBE</b>		
Standard	HSKLB	p. 287
<b>06 CHIAVE PER RACCORDO REFRIGERANTE   COOLANT TUBE WRENCH</b>		
Standard	CVLB	p. 276



01



02



03



04



05



06

# HSKERM

## PORTAPINZE ER MINI (DIN 6499) COLLET CHUCKS ER MINI (DIN 6499)

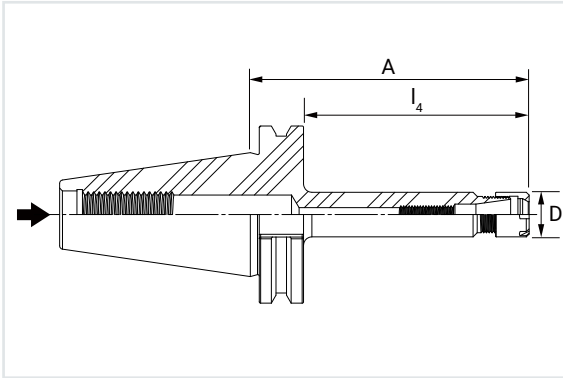

### Dettagli tecnici | Technical details

Applicazione | Application

Forma | Form

Grado di bilanciatura | Degree of balancing

Run Out

Accessori forniti | Accessories provided

Elenco Accessori e Ricambi a richiesta  
List of Accessories & Spare parts on request

Per utensili con codolo cilindrico in differenti tolleranze  
For tools with cylindrical shank in different tolerances

HSK A

G 6.3 18.000 giri/min | G 6.3 18.000 rpm

Max. 3 µm

Ghiera di bloccaggio mini | Mini clamp nut

Vedi pagina 135 | See page 135

Codice d'ordine  
Order Code

STATUS

SK	ER	A	l <sub>4</sub>	D
----	----	---	----------------	---

#### HSKERM 63

HSKERM 63X11X100	NEW ●
HSKERM 63X11X125	NEW ●
HSKERM 63X11X160	NEW ●
HSKERM 63X16X100	NEW ●
HSKERM 63X16X125	NEW ●
HSKERM 63X16X160	NEW ●
HSKERM 63X20X100	NEW ●

63	11	100	74	16
63	11	125	93	16
63	11	160	134	16
63	16	100	74	22
63	16	125	98.6	22
63	16	160	134	22
63	20	100	74	28

La gamma prosegue nella pagina successiva | The range continues on the next page >>

Codice d'ordine Order Code	STATUS	SK	ER	A	I <sub>4</sub>	D
<b>HSKERM 63</b>						
HSKERM 63X20X110	NEW ●	63	20	110	84	28
HSKERM 63X20X160	NEW ●	63	20	160	134	28
HSKERM 63X25X100	NEW ●	63	25	100	74	35
HSKERM 63X25X125	NEW ●	63	25	125	99	35
HSKERM 63X25X160	NEW ●	63	25	160	134	35
<b>HSKERM 100</b>						
HSKERM 100X16X160	NEW ●	100	16	160	131	22

## Accessori e Ricambi | Accessories & Spare Parts

	Codice Code	Pagina Page
<b>01 PINZE ER   ER COLLETS</b>		
Standard	PZER	p. 216
Ultra precise   High precision	ERUP	p. 223
Vulcanizzate   Rubber sealed collets	ERVU	p. 229
Con quadro interno   With internal square	PZSQ	p. 233
A tenuta con fori di lubrificazione   Externally cooled collets	PZERJ	p. 236
<b>02 GHIERA DI BLOCCAGGIO ER   ER CLAMP NUT</b>		
Mini	GRERA	p. 256
<b>03 CHIAVE DI BLOCCAGGIO ER   ER WRENCH CLAMP</b>		
Mini	CVERM	p. 277
<b>04 PROLUNGHE PER PORTA PINZE ER (MINI)   EXTENSIONS FOR ER COLLET CHUCKS (MINI)</b>		
Prolunghe Cilindriche   Cylindrical Extensions	PGCLM	p. 204
Prolunghe Weldon   Weldon Extensions	PGWEM	p. 208
<b>05 RACCORDO PER REFRIGERANTE   COOLANT TUBE</b>		
Standard	HSKLB	p. 287
<b>06 CHIAVE PER RACCORDO REFRIGERANTE   COOLANT TUBE WRENCH</b>		
Standard	CVLB	p. 276



01



02



03



04



05



06

# HSKWE

## ATTACCO WELDON WELDON HOLDERS

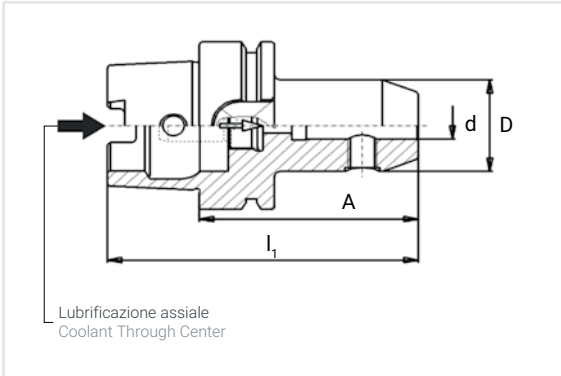

### Dettagli tecnici | Technical details

Applicazione | Application

Forma | Form

Grado di bilanciatura | Degree of balancing

Run Out

Accessori forniti | Accessories provided

Elenco Accessori e Ricambi a richiesta  
List of Accessories & Spare parts on request

Per utensili con codolo cilindrico tipo weldon secondo norma DIN 1835B.  
For tools with weldon type cylindrical shank according to DIN 1835B.

HSK A

G 6.3 20.000 giri/min | G 6.3 20.000 rpm

Max. 15 µm (3 x d)

Vite di bloccaggio | Clamping screw

Vedi pagina 139 | See page 139

Codice d'ordine  
Order Code

STATUS

#### HSKWE 63

HSKWE 63X6X65	●
HSKWE 63X6X100	NEW ●
HSKWE 63X6X160	●
HSKWE 63X8X65	●
HSKWE 63X8X100	NEW ●
HSKWE 63X8X160	●
HSKWE 63X10X65	●

SK	d	A	l <sub>1</sub>	D
----	---	---	----------------	---

63	6	65	97	25
63	6	100	132	25
63	6	160	192	25
63	8	65	97	28
63	8	100	132	28
63	8	160	192	28
63	10	65	97	35

La gamma prosegue nella pagina successiva | The range continues on the next page >>



Codice d'ordine Order Code	STATUS	SK	d	A	I <sub>1</sub>	D
<b>HSKWE 63</b>						
HSKWE 63X10X100	NEW ●	63	10	100	132	35
HSKWE 63X10X160	●	63	10	160	192	35
HSKWE 63X12X80	●	63	12	80	112	42
HSKWE 63X12X100	NEW ●	63	12	100	132	42
HSKWE 63X12X160	●	63	12	160	192	42
HSKWE 63X14X80	●	63	14	80	112	44
HSKWE 63X14X160	●	63	14	160	192	44
HSKWE 63X16X80	●	63	16	80	112	48
HSKWE 63X16X100	NEW ●	63	16	100	132	48
HSKWE 63X16X160	●	63	16	160	192	48
HSKWE 63X18X80	●	63	18	80	112	50
HSKWE 63X18X160	●	63	18	160	192	50
HSKWE 63X20X80	●	63	20	80	112	52
HSKWE 63X20X100	●	63	20	100	132	52
HSKWE 63X20X160	●	63	20	160	192	52
HSKWE 63X25X110	●	63	25	110	142	65
HSKWE 63X25X160	NEW ●	63	25	160	192	65
HSKWE 63X32X110	●	63	32	110	142	72
<b>HSKWE 100</b>						
HSKWE 100X6X80	NEW ●	100	6	80	130	25
HSKWE 100X6X160	●	100	6	160	210	25
HSKWE 100X8X80	NEW ●	100	8	80	130	28
HSKWE 100X8X160	●	100	8	160	210	28
HSKWE 100X10X80	NEW ●	100	10	80	130	35
HSKWE 100X10X160	●	100	10	160	210	35
HSKWE 100X12X80	NEW ●	100	12	80	130	42
HSKWE 100X12X160	●	100	12	160	210	42
HSKWE 100X14X80	NEW ●	100	14	80	130	44
HSKWE 100X16X100	●	100	16	100	150	48
HSKWE 100X16X160	●	100	16	160	210	48
HSKWE 100X18X100	●	100	18	100	150	50
HSKWE 100X20X100	●	100	20	100	150	52
HSKWE 100X20X160	●	100	20	160	210	52
HSKWE 100X25X100	NEW ●	100	25	100	150	65
HSKWE 100X25X160	NEW ●	100	25	160	210	65
HSKWE 100X32X100	NEW ●	100	32	100	150	72
HSKWE 100X40X105	NEW ●	100	40	105	155	80

HSK - DIN 69893

**HSKWEG**

**ATTACCO WELDON CON CANALINI DI LUBRIFICAZIONE**  
**WELDON HOLDERS WITH COOLANT GROOVES**

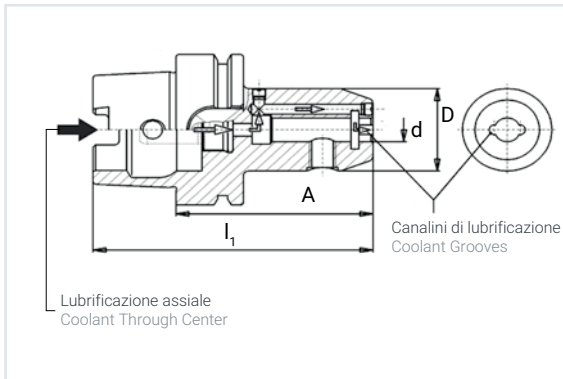

**Dettagli tecnici | Technical details**

Applicazione   Application	Per utensili con codolo cilindrico tipo weldon secondo norma DIN 1835B. For tools with weldon type cylindrical shank according to DIN 1835B.
Forma   Form	HSK A
Grado di bilanciatura   Degree of balancing	G 6.3 20.000 giri/min   G 6.3 20.000 rpm
Run Out	Max. 15 µm (3 x d)
Accessori forniti   Accessories provided	Vite di bloccaggio   Clamping screw
Elenco Accessori e Ricambi a richiesta List of Accessories & Spare parts on request	Vedi pagina 139   See page 139

Codice d'ordine Order Code	STATUS
-------------------------------	--------

**HSKWEG 63**

HSKWEG 63X6X65	●
HSKWEG 63X8X65	●
HSKWEG 63X10X65	●
HSKWEG 63X12X80	●
HSKWEG 63X14X80	●
HSKWEG 63X16X80	●
HSKWEG 63X18X80	●

SK	d	A	I <sub>1</sub>	D
63	6	65	97	25
63	8	65	97	28
63	10	65	97	35
63	12	80	112	42
63	14	80	112	44
63	16	80	112	48
63	18	80	112	50

La gamma prosegue nella pagina successiva | The range continues on the next page >>

Codice d'ordine Order Code	STATUS	SK	d	A	I <sub>1</sub>	D
<b>HSKWEG 63</b>						
HSKWEG 63X20X80	●	63	20	80	112	52
HSKWEG 63X25X110	●	63	25	110	142	65
HSKWEG 63X32X110	●	63	32	110	142	72
HSKWEG 63X40X125	●	63	40	125	157	80

## Accessori e Ricambi (HSKWE-HSKWEG) | Accessories & Spare Parts (HSKWE-HSKWEG)

	Codice Code	Pagina Page
<b>01 MANDRINO A CAMBIO RAPIDO   QUICK CHANGE TAPPING CHUCK</b>		
Standard	WEMS	p. 284
<b>02 RIDUZIONI PER ATTACCO WELDON   REDUCTIONS FOR WELDON HOLDERS</b>		
Standard	RWE	p. 282
<b>03 PROLUNGHE WELDON PER PORTA PINZE ER   WELDON EXTENSIONS FOR ER COLLET CHUCKS</b>		
Standard	PGWE	p. 206
<b>04 VITE DI BLOCCAGGIO   CLAMPING SCREW</b>		
Standard	SWE ..	p. 280
<b>05 RACCORDO PER REFRIGERANTE   COOLANT TUBE</b>		
Standard	HSKLB	p. 287
<b>06 CHIAVE PER RACCORDO REFRIGERANTE   COOLANT TUBE WRENCH</b>		
Standard	CVLB	p. 276



## HSKWN

### ATTACCO WHISTLE NOTCH WHISTLE-NOTCH HOLDERS

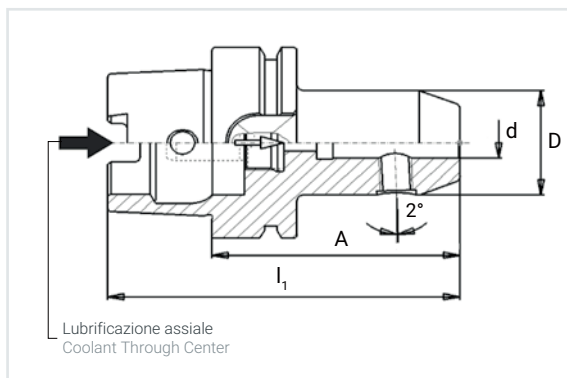

#### Dettagli tecnici | Technical details

Applicazione | Application

Forma | Form

Grado di bilanciatura | Degree of balancing

Run Out

Accessori forniti | Accessories provided

Elenco Accessori e Ricambi a richiesta  
List of Accessories & Spare parts on request

Per utensili con codolo cilindrico tipo whistle-notch secondo norma DIN 1835E | 6359HE.  
For tools with whistle-notch cylindrical shank according to DIN 1835E | 6359HE.

HSK A

G 6.3 15.000 giri/min | G 6.3 15.000 rpm

Max. 15 µm (3 x d)

Vite di bloccaggio | Clamping screw

Vedi pagina 141 | See page 141

Codice d'ordine  
Order Code

STATUS

SK

d

A

l<sub>1</sub>

D

#### HSKWN 63

HSKWN 63X6X80	●
HSKWN 63X8X80	●
HSKWN 63X10X80	●
HSKWN 63X12X90	●
HSKWN 63X14X90	●
HSKWN 63X16X100	●
HSKWN 63X18X100	●

63	6	80	112	25
63	8	80	112	28
63	10	80	112	35
63	12	90	122	42
63	14	90	122	44
63	16	100	132	48
63	18	100	132	50

La gamma prosegue nella pagina successiva | The range continues on the next page >>

Codice d'ordine Order Code	STATUS	SK	d	A	I <sub>1</sub>	D
<b>HSKWN 63</b>						
HSKWN 63X20X105	●	63	20	105	137	52
HSKWN 63X25X110	●	63	25	110	142	65
HSKWN 63X32X110	●	63	32	110	142	72
<b>HSKWN 100</b>						
HSKWN 100X6X90	●	100	6	90	140	25
HSKWN 100X8X90	●	100	8	90	140	28
HSKWN 100X10X90	●	100	10	90	140	35
HSKWN 100X12X100	●	100	12	100	150	42
HSKWN 100X14X100	●	100	14	100	150	44
HSKWN 100X16X100	●	100	16	100	150	48
HSKWN 100X18X100	●	100	18	100	150	50
HSKWN 100X20X110	●	100	20	110	160	52
HSKWN 100X25X120	●	100	25	120	170	65
HSKWN 100X32X120	●	100	32	120	170	72
HSKWN 100X40X130	●	100	40	130	180	80

## Accessori e Ricambi | Accessories & Spare Parts

	Codice Code	Pagina Page
<b>01 VITE DI BLOCCAGGIO   CLAMPING SCREW</b>		
Standard	SWE ..	p. 280
<b>02 RACCORDO PER REFRIGERANTE   COOLANT TUBE</b>		
Standard	HSKLB	p. 287
<b>03 CHIAVE PER RACCORDO REFRIGERANTE   COOLANT TUBE WRENCH</b>		
Standard	CVLB	p. 276

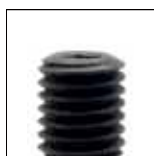

01



02



03

# HSKFI

## PORTAFRESE FISSI (DIN 6357) SHELL END MILL HOLDERS (DIN 6357)

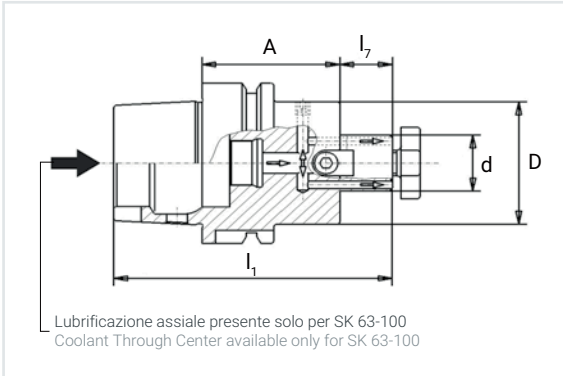

### Dettagli tecnici | Technical details

Applicazione   Application	Per frese con scanalatura trasversale For end mills with cross groove
Forma   Form	HSK A
Grado di bilanciatura   Degree of balancing	G 6.3 15.000 giri/min   G 6.3 15.000 rpm
Run Out	Max. 8 µm
Accessori forniti   Accessories provided	Con due chiavette di trascinamento fisse e vite di bloccaggio DIN 6367 With two fixed drive keys and clamping screw DIN 6367
Elenco Accessori e Ricambi a richiesta List of Accessories & Spare parts on request	Vedi pagina 144   See page 144

Codice d'ordine Order Code	STATUS
-------------------------------	--------

HSKFI 40	
HSKFI 40X16X45	NEW ●
HSKFI 40X22X50	NEW ●
HSKFI 40X27X55	NEW ●

HSKFI 50	
HSKFI 50X16X50	NEW ●
HSKFI 50X22X60	NEW ●

SK	d	A	l <sub>1</sub>	l <sub>7</sub>	D
40	16	45	65	17	38
40	22	50	70	19	48
40	27	55	75	21	58
50	16	50	70	17	38
50	22	60	80	21	58

La gamma prosegue nella pagina successiva | The range continues on the next page >>

Codice d'ordine Order Code	STATUS	SK	d	A	l <sub>1</sub>	l <sub>2</sub>	D
<b>HSKFI 50</b>							
HSKFI 50X27X60	NEW ●	50	27	60	85	24	78
HSKFI 50X32X60	NEW ●	50	32	60	85	24	78
<b>HSKFI 63</b>							
HSKFI 63X16X45	●	63	16	45	94	17	38
HSKFI 63X16X100	NEW ●	63	16	100	149	17	38
HSKFI 63X16X160	●	63	16	160	209	17	38
HSKFI 63X22X50	●	63	22	50	101	19	48
HSKFI 63X22X100	NEW ●	63	22	100	151	19	48
HSKFI 63X22X160	●	63	22	160	211	19	48
HSKFI 63X27X60	●	63	27	60	113	21	58
HSKFI 63X27X100	NEW ●	63	27	100	153	21	58
HSKFI 63X27X160	●	63	27	160	213	21	58
HSKFI 63X32X60	●	63	32	60	116	24	78
HSKFI 63X32X100	NEW ●	63	32	100	156	24	78
HSKFI 63X32X160	●	63	32	160	216	24	78
HSKFI 63X40X60	●	63	40	60	119	27	88
HSKFI 63X40X100	NEW ●	63	40	100	159	27	88
HSKFI 63X40X160	●	63	40	160	219	27	88
<b>HSKFI 100</b>							
HSKFI 100X16X50	NEW ●	100	16	50	117	17	38
HSKFI 100X16X160	NEW ●	100	16	160	227	17	38
HSKFI 100X22X50	NEW ●	100	22	50	119	19	48
HSKFI 100X22X160	NEW ●	100	22	160	229	19	48
HSKFI 100X27X50	NEW ●	100	27	50	121	21	58
HSKFI 100X27X160	NEW ●	100	27	160	231	21	58
HSKFI 100X32X50	NEW ●	100	32	50	124	24	78
HSKFI 100X32X160	NEW ●	100	32	160	239	24	78
HSKFI 100X40X60	NEW ●	100	40	60	137	27	88
HSKFI 100X40X160	NEW ●	100	40	160	242	27	88
HSKFI 100X50X70	NEW ●	100	50	70	150	30	129
HSKFI 100X60X70	NEW ●	100	60	70	160	40	129

Accessori e Ricambi alla pagina successiva | Accessories and Spare Parts on the next page >>

Accessori e Ricambi | Accessories & Spare Parts

	Codice Code	Pagina Page
<b>01 CHIAVE DI BLOCCAGGIO   CLAMPING WRENCH</b> Standard	CVCR	p. 279
<b>02 VITE DI BLOCCAGGIO   CLAMPING SCREW</b> Standard	VTGR	p. 281
<b>03 RACCORDO PER REFRIGERANTE   COOLANT TUBE</b> Standard	HSKLB	p. 287
<b>04 CHIAVE PER RACCORDO REFRIGERANTE   COOLANT TUBE WRENCH</b> Standard	CVLB	p. 276
<b>05 PROLUNGHE PER PORTA FRESE   EXTENSIONS FOR SHELL END MILLS HOLDERS</b> Standard	PRFI	p. 212



01



02



03



04



05



## HSKAC

### PORTAFRESE COMBINATI (DIN 6358) COMBI SHELL END MILL HOLDERS (DIN 6358)

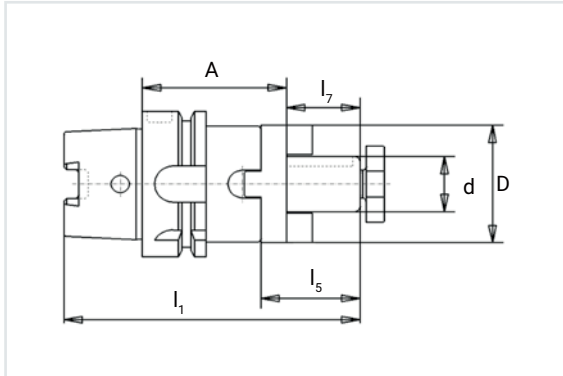

HSK - DIN 69893

#### Dettagli tecnici | Technical details

Applicazione   Application	Per frese con scanalatura longitudinale o trasversale For end mills with longitudinal and cross groove
Forma   Form	HSK A
Grado di bilanciatura   Degree of balancing	G 6.3 15.000 giri/min   G 6.3 15.000 rpm
Run Out	Max. 8 µm
Accessori forniti   Accessories provided	Con Vite di bloccaggio DIN 6367, anello di trascinamento DIN 6366 e chiave di bloccaggio. With clamping screw DIN 6367, drive ring DIN 6366 and feather key.
Elenco Accessori e Ricambi a richiesta List of Accessories & Spare parts on request	Vedi pagina 147   See page 147

Codice d'ordine Order Code	STATUS	SK	d	A	l <sub>1</sub>	l <sub>5</sub>	l <sub>7</sub>	D
<b>HSKAC 40</b>								
HSKAC 40X16X50	NEW ●	40	16	50	87	27	17	32
HSKAC 40X22X50	NEW ●	40	22	50	89	31	19	40
HSKAC 40X27X65	NEW ●	40	27	65	106	33	21	48
<b>HSKAC 50</b>								
HSKAC 50X16X50	NEW ●	50	16	50	92	27	17	32
HSKAC 50X22X50	NEW ●	50	22	50	94	31	19	40

La gamma prosegue nella pagina successiva | The range continues on the next page >>

Codice d'ordine Order Code	STATUS
-------------------------------	--------

SK	d	A	l <sub>1</sub>	l <sub>5</sub>	l <sub>7</sub>	D
----	---	---	----------------	----------------	----------------	---

**HSKAC 50**

HSKAC 50X27X65	NEW ●
HSKAC 50X32X65	NEW ●

50	27	65	106	33	21	48
50	32	65	109	38	24	58

**HSKAC 63**

HSKAC 63X16X60	NEW ●
HSKAC 63X16X100	NEW ●
HSKAC 63X16X160	NEW ●
HSKAC 63X22X60	NEW ●
HSKAC 63X22X100	NEW ●
HSKAC 63X22X160	NEW ●
HSKAC 63X27X60	NEW ●
HSKAC 63X27X100	NEW ●
HSKAC 63X27X160	NEW ●
HSKAC 63X32X60	NEW ●
HSKAC 63X32X100	NEW ●
HSKAC 63X32X160	NEW ●
HSKAC 63X40X70	NEW ●
HSKAC 63X40X100	NEW ●
HSKAC 63X40X160	NEW ●

63	16	60	109	27	17	32
63	16	100	149	27	17	32
63	16	160	209	27	17	32
63	22	60	111	31	19	40
63	22	100	151	31	19	40
63	22	160	211	31	19	40
63	27	60	113	33	21	48
63	27	100	153	33	21	48
63	27	160	213	33	21	48
63	32	60	116	38	24	58
63	32	100	156	38	24	58
63	32	160	216	38	24	58
63	40	70	129	41	27	70
63	40	100	159	41	27	70
63	40	160	219	41	27	70

**HSKAC 100**

HSKAC 100X16X60	NEW ●
HSKAC 100X22X60	NEW ●
HSKAC 100X27X60	NEW ●
HSKAC 100X32X60	NEW ●
HSKAC 100X40X70	NEW ●

100	16	60	127	27	17	32
100	22	60	129	31	19	40
100	27	60	131	33	21	48
100	32	60	134	38	24	58
100	40	70	137	41	27	70

## Accessori e Ricambi | Accessories & Spare Parts

	Codice Code	Pagina Page
<b>01 ANELLO DI TRASCINAMENTO   DRIVE RING</b> Standard	ANTR	p. 286
<b>03 CHIAVE DI BLOCCAGGIO   CLAMPING WRENCH</b> Standard	CVCR	p. 279
<b>03 VITE DI BLOCCAGGIO   CLAMPING SCREW</b> Standard	VTGR	p. 281
<b>04 RACCORDO PER REFRIGERANTE   COOLANT TUBE</b> Standard	HSKLB	p. 287
<b>05 CHIAVE PER RACCORDO REFRIGERANTE   COOLANT TUBE WRENCH</b> Standard	CVLB	p. 276



01



02



03



04



05

**HSKDS - HSKDSB**

**PORTAPUNTE AUTOSERRANTI  
(ALTA PRECISIONE)  
DRILL CHUCKS (HIGH PRECISION)**

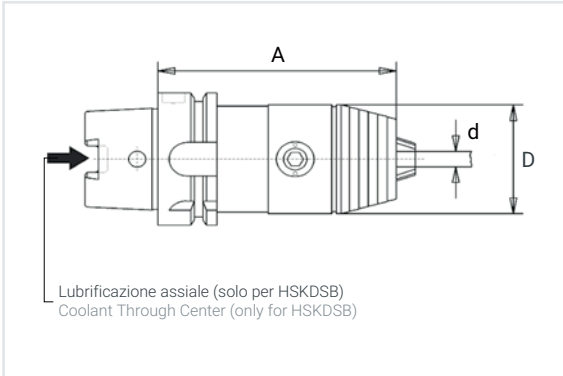

**Dettagli tecnici | Technical details**

Applicazione   Application	Per punte con codolo cilindrico in differenti tolleranze For drills with cylindrical shank in different tolerances
Forma   Form	HSK A
Grado di bilanciatura   Degree of balancing	-
Run Out	Max. 20 µm (3 x d)
Accessori forniti   Accessories provided	Chiave   Key
Elenco Accessori e Ricambi a richiesta List of Accessories & Spare parts on request	Vedi pagina 149   See page 149

Codice d'ordine Order Code	STATUS
-------------------------------	--------

**HSKDS 63**

HSKDS 63X13	●
HSKDS 63X16	●

**HSKDS 100**

HSKDS 100X13	●
HSKDS 100X16	●

SK	d	A	D	Range
63	13	104	50	1-13
63	16	109	57	2,5-16
100	13	111	50	1-13
100	16	116	57	2,5-16

La gamma prosegue nella pagina successiva | The range continues on the next page >>

Codice d'ordine Order Code	STATUS	SK	d	A	D	Range
<b>HSKDSB 63</b>						
HSKDSB 63X13	●	63	13	104	50	1-13
HSKDSB 63X16	●	63	16	109	57	2,5-16
<b>HSKDSB 100</b>						
HSKDSB 100X13	●	100	13	111	50	1-13
HSKDSB 100X16	●	100	16	116	57	2,5-16

## Accessori e Ricambi | Accessories & Spare Parts

	Codice Code	Pagina Page
<b>01 RACCORDO PER REFRIGERANTE   COOLANT TUBE</b>		
Standard	HSKLB	p. 287
<b>02 CHIAVE PER RACCORDO REFRIGERANTE   COOLANT TUBE WRENCH</b>		
Standard	CVLB	p. 276



01



02

# HSKMS

## PORTA MASCHI TAPPING CHUCKS

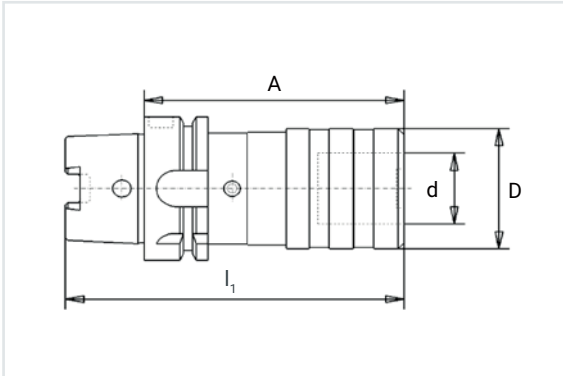

### Dettagli tecnici | Technical details

Applicazione | Application

Per bussole porta maschio a cambio rapido con compensazione assiale  
For quick change tapping chuck with axial compensation

Forma | Form

HSK A

Grado di bilanciatura | Degree of balancing

-

Run Out

-

Accessori forniti | Accessories provided

-

Elenco Accessori e Ricambi a richiesta  
List of Accessories & Spare parts on request

Vedi pagina 151 | See page 151

Codice d'ordine  
Order Code

STATUS

#### HSKMS 63

HSKMS 63X1	●
HSKMS 63X2	●

#### HSKMS 100

HSKMS 100X1	●
HSKMS 100X2	●
HSKMS 100X3	●

SK	Tipo Type	d	A	l <sub>1</sub>	D
63	1	19	102	134	38
63	2	31	152	184	54
100	1	19	112	162	38
100	2	31	100	150	54
100	3	48	144	194	86

## Accessori e Ricambi | Accessories & Spare Parts

	Codice Code	Pagina Page
<b>01 PINZE CON FRIZIONE   TAPPING COLLETS WITH CLUTCH</b>		
Standard	PZCFR	p. 242
<b>02 PINZE SENZA FRIZIONE   TAPPING COLLETS WITHOUT CLUTCH</b>		
Standard	PZSFR	p. 244
<b>03 RACCORDO PER REFRIGERANTE   COOLANT TUBE</b>		
Standard	HSKLB	p. 287
<b>04 CHIAVE PER RACCORDO REFRIGERANTE   COOLANT TUBE WRENCH</b>		
Standard	CVLB	p. 276



01



02



03



04

## HSKCM

### ATTACCO CONO MORSE PER PUNTE (DIN 6383) MORSE TAPER FOR DRILLS (DIN 6383)

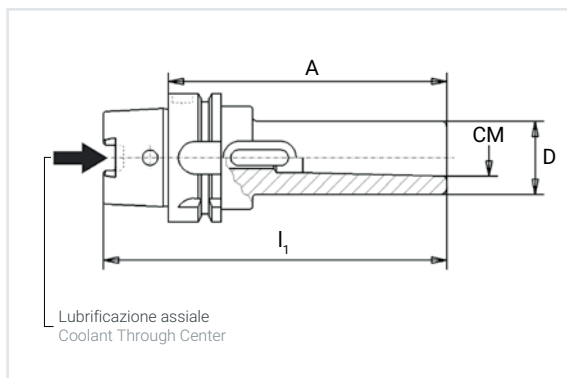

#### Dettagli tecnici | Technical details

Applicazione   Application	Per punte attacco cono morse For drills with cono morse shank
Forma   Form	HSK A
Grado di bilanciatura   Degree of balancing	G 6.3 20.000 giri/min   G 6.3 20.000 rpm
Run Out	Max. 10 µm
Accessori forniti   Accessories provided	-
Elenco Accessori e Ricambi a richiesta List of Accessories & Spare parts on request	Vedi pagina 153   See page 153

Codice d'ordine Order Code	STATUS	SK	CM	A	l <sub>1</sub>	D
<b>HSKCM 63</b>						
HSKCM 63X1X100	●	63	1	100	132	25
HSKCM 63X2X120	●	63	2	120	152	32
HSKCM 63X3X140	●	63	3	140	172	40
HSKCM 63X4X160	●	63	4	160	192	48

La gamma prosegue nella pagina successiva | The range continues on the next page >>



Codice d'ordine Order Code	STATUS	SK	CM	A	I <sub>1</sub>	D
<b>HSKCM 100</b>						
HSKCM 100X2X120	●	100	2	120	170	32
HSKCM 100X3X150	●	100	3	150	200	40
HSKCM 100X4X170	●	100	4	170	220	48

## Accessori e Ricambi | Accessories & Spare Parts

	Codice Code	Pagina Page
<b>01 RACCORDO PER REFRIGERANTE   COOLANT TUBE</b>		
Standard	HSKLB	p. 287
<b>02 CHIAVE PER RACCORDO REFRIGERANTE   COOLANT TUBE WRENCH</b>		
Standard	CVLB	p. 276
<b>03 TENONE DI ESPULSIONE   TANGS TO SCREW IN</b>		
Standard	TEVT	p. 273



01



02



03

## HSKMK

### ATTACCO CONO MORSE PER FRESE (DIN 6364) MORSE TAPER FOR END MILLS (DIN 6364)

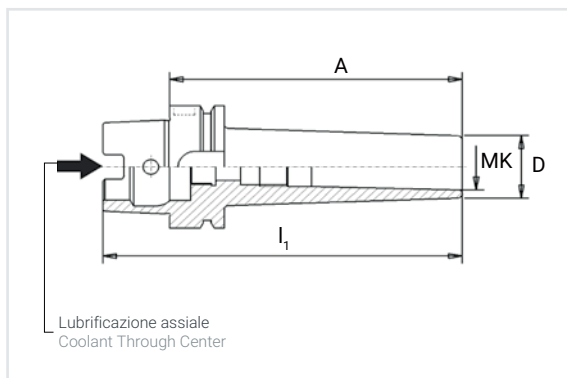

#### Dettagli tecnici | Technical details

Applicazione | Application

Per frese attacco cono morse  
For end mills with cono morse shank

Forma | Form

HSK A

Grado di bilanciatura | Degree of balancing

G 6.3 20.000 giri/min | G 6.3 20.000 rpm

Run Out

Max. 10 µm

Accessori forniti | Accessories provided

Vite di bloccaggio | Clamping screw

Elenco Accessori e Ricambi a richiesta  
List of Accessories & Spare parts on request

Vedi pagina 155 | See page 155

Codice d'ordine  
Order Code

STATUS

SK

MK

A

I<sub>1</sub>

D

#### HSKMK 63

HSKMK 63X1X100	●
HSKMK 63X2X120	●
HSKMK 63X3X140	●
HSKMK 63X4X160	●

63	1	100	132	25
63	2	120	152	32
63	3	140	172	40
63	4	160	192	48

La gamma prosegue nella pagina successiva | The range continues on the next page >>

Codice d'ordine Order Code	STATUS	SK	MK	A	I <sub>1</sub>	D
<b>HSKMK 100</b>						
HSKMK 100X2X120	●	100	2	120	170	32
HSKMK 100X3X150	●	100	3	150	200	40
HSKMK 100X4X170	●	100	4	170	220	48

## Accessori e Ricambi | Accessories & Spare Parts

	Codice Code	Pagina Page
<b>01 RACCORDO PER REFRIGERANTE   COOLANT TUBE</b>		
Standard	HSKLB	p. 287
<b>02 CHIAVE PER RACCORDO REFRIGERANTE   COOLANT TUBE WRENCH</b>		
Standard	CVLB	p. 276



01



02

# HSKSL

## SEMI LAVORATO BLANK BARS

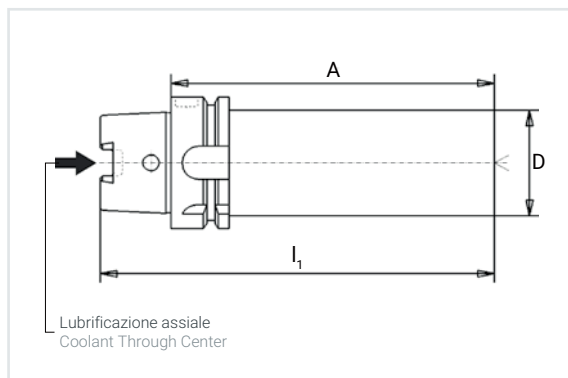

### Dettagli tecnici | Technical details

Applicazione | Application

Per la produzione di mandrini speciali  
For the production of special tool holders

Forma | Form

HSK A

Elenco Accessori e Ricambi a richiesta  
List of Accessories & Spare parts on request

Tiranti (vedi pagina 260-261) | Pull Studs (see page 260-261)

Codice d'ordine Order Code	STATUS
-------------------------------	--------

SK	A	l <sub>1</sub>	D
----	---	----------------	---

#### HSKSL 63

HSKSL 63X63X160	NEW ●
HSKSL 63X63X250	NEW ●
HSKSL 63X80X250	NEW ●

63	160	192	63
63	250	282	63
63	250	282	80

#### HSKSL 100

HSKSL 100X63X200	NEW ●
HSKSL 100X90X300	NEW ●

100	200	250	63
100	300	350	90

## HSKCK

### BARRE DI CONTROLLO TEST ARBORS

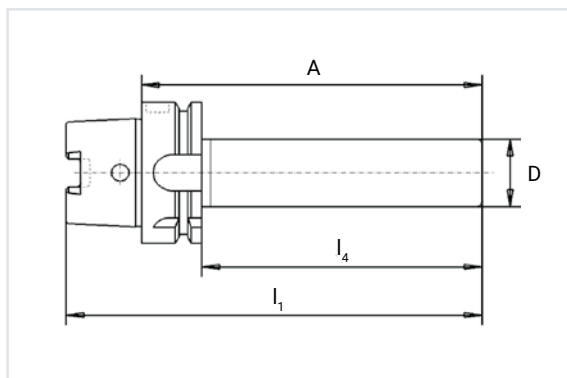

HSK - DIN 69893

#### Dettagli tecnici | Technical details

Applicazione | Application

Per controllo accurato della rotazione del mandrino  
For testing of accuracy of machine spindle

Run Out

Max. 3  $\mu$ m

Accessori e Ricambi a richiesta  
Accessories & Spare parts on request

Tiranti (vedi pagina 260-261) | Pull Studs (see page 260-261)

Codice d'ordine Order Code	STATUS	SK	A	$l_1$	$l_4$	D
<b>HSKCK 63</b>						
HSKCK 63X40X300	●	63	300	332	274	40
<b>HSKCK 100</b>						
HSKCK 100X50X300	●	100	300	350	271	50



NEW

p. 160-162

## PLGER

Portapinze ER  
(DIN 6499)  
Collet Chucks ER  
(DIN 6499)



NEW

p. 163-165

## PLGWE

Attacco Weldon  
Weldon Holders



NEW

p. 166-167

## PLGFI

Portafrese Fissi  
(DIN 6357)  
Shell End Mill Holders  
(DIN 6357)



NEW

p. 168

## PLGIX

Portapunte a  
Fissaggio Meccanico  
Indexable  
Drill Holders



# POLYGONAL - ISO 26623-1

Indice di sezione | Section Index



**NEW**

**p. 169-170**

## **PLGMS**

Porta Maschi  
Tapping Chucks



**NEW**

**p. 171**

## **PLGSL**

Semi Lavorato  
Blank Bars

POLYGONAL

## PLGER

### PORTAPINZE ER (DIN 6499) COLLET CHUCKS ER (DIN 6499)

POLYGONAL

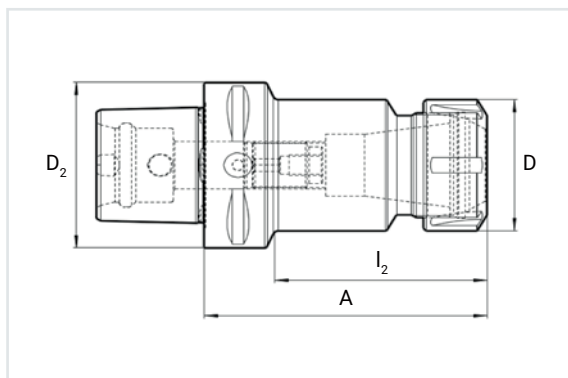

#### Dettagli tecnici | Technical details

Applicazione | Application

Per utensili con codolo cilindrico in differenti tolleranze  
For tools with cylindrical shank in different tolerances

Grado di bilanciatura | Degree of balancing

G 6.3 20.000 giri/min | G 6.3 20.000 rpm

Run Out

Max. 5 µm

Accessori forniti | Accessories provided

Ghiera di bloccaggio standard | Standard clamp nut

Elenco Accessori e Ricambi a richiesta  
List of Accessories & Spare parts on request

Vedi pagina 162 | See page 162

Codice d'ordine  
Order Code

STATUS

C	ER	A	I <sub>2</sub>	D	D <sub>2</sub>	Gamma Range
---	----	---	----------------	---	----------------	-------------

#### PLGER 40

PLGER 40X16X70	NEW ●
PLGER 40X25X52	NEW ●

40	16	70	44	28	40	1-10mm
40	25	52	--	42	40	2-16mm

#### PLGER 50

PLGER 50X16X100	NEW ●
PLGER 50X25X55	NEW ●
PLGER 50X32X57	NEW ●

50	16	100	60	28	50	1-10mm
50	25	55	33	42	50	2-16mm
50	32	57	--	50	50	2-20mm

La gamma prosegue nella pagina successiva | The range continues on the next page >>



# POLYGONAL - ISO 26623-1 [PLGER]

Portapinze ER (DIN 6499) | Collet Chucks ER (DIN 6499)

Codice d'ordine Order Code	STATUS	C	ER	A	I <sub>2</sub>	D	D <sub>2</sub>	Gamma Range
<b>PLGER 63</b>								
PLGER 63X16X100	NEW ●	63	16	100	60	28	63	1-10mm
PLGER 63X25X60	NEW ●	63	25	60	33	42	63	2-16mm
PLGER 63X25X100	NEW ●	63	25	100	75	42	63	2-16mm
PLGER 63X32X60	NEW ●	63	32	60	35	50	63	2-20mm
PLGER 63X32X100	NEW ●	63	32	100	75	50	63	2-20mm
PLGER 63X40X65	NEW ●	63	40	65	--	63	63	3-26mm
PLGER 63X40X130	NEW ●	63	40	130	--	63	63	3-26mm
<b>PLGER 80</b>								
PLGER 80X25X70	NEW ●	80	25	70	32	42	80	2-16mm
PLGER 80X32X70	NEW ●	80	32	70	35	50	80	2-20mm
PLGER 80X40X70	NEW ●	80	40	70	38	63	80	3-26mm

Accessori e Ricambi | Accessories & Spare Parts

POLYGONAL

	Codice Code	Pagina Page
<b>01 PINZE ER   ER COLLETS</b>		
Standard	PZER	p. 216
Ultra precise   High precision	ERUP	p. 223
Vulcanizzate   Rubber sealed collets	ERVU	p. 229
Con quadro interno   With internal square	PZSQ	p. 233
A tenuta con fori di lubrificazione   Externally cooled collets	PZERJ	p. 236
<b>02 GHIERA DI BLOCCAGGIO ER   ER CLAMP NUT</b>		
Standard	GRERB	p. 256
Bilanciata   Balanced	GRERC	p. 256
Per forte serraggio   For high clamping power	GRERD	p. 257
Con anello di tenuta   With sealing disk	GRERE	p. 257
Con anello di tenuta a step di 0.5 mm   With sealing disk in 0.5 mm steps	GRERF	p. 257
<b>03 CHIAVE DI BLOCCAGGIO ER   ER WRENCH CLAMP</b>		
Standard	CVER	p. 277
<b>04 PROLUNGHE CILINDRICHE PER PORTA PINZE ER   CYLINDRICAL EXTENSIONS FOR ER COLLET CHUCKS</b>		
Standard	PGCL	p. 202



01



02



03



04

## PLGWE

### ATTACCO WELDON WELDON HOLDERS

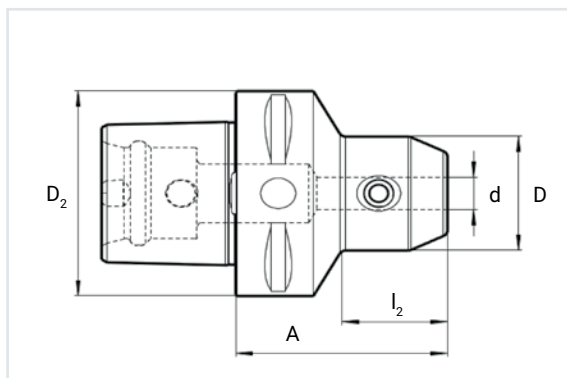

POLYGONAL

#### Dettagli tecnici | Technical details

Applicazione   Application
Grado di bilanciatura   Degree of balancing
Run Out
Accessori forniti   Accessories provided
Elenco Accessori e Ricambi a richiesta List of Accessories & Spare parts on request

Per utensili con codolo cilindrico tipo weldon secondo norma DIN 1835B. For tools with weldon type cylindrical shank according to DIN 1835B.
G 6.3 20.000 giri/min   G 6.3 20.000 rpm
Max. 15 µm (3 x d)
Vite di bloccaggio   Clamping screw
Vedi pagina 165   See page 165

Codice d'ordine Order Code	STATUS
-------------------------------	--------

PLGWE 40	
PLGWE 40X6X50	NEW ●
PLGWE 40X8X50	NEW ●
PLGWE 40X10X51	NEW ●
PLGWE 40X12X55	NEW ●
PLGWE 40X16X55	NEW ●

C	d	A	l <sub>2</sub>	D	D <sub>2</sub>
40	6	50	25	25	40
40	8	50	26	28	40
40	10	51	29	35	40
40	12	55	--	42	40
40	16	55	--	48	40

La gamma prosegue nella pagina successiva | The range continues on the next page >>

Codice d'ordine Order Code	STATUS	C	d	A	I <sub>2</sub>	D	D <sub>2</sub>
<b>PLGWE 50</b>							
PLGWE 50X10X55	NEW ●	50	10	55	28	35	50
PLGWE 50X12X60	NEW ●	50	12	60	36	42	50
PLGWE 50X20X60	NEW ●	50	20	60	--	52	50
PLGWE 50X25X80	NEW ●	50	25	80	--	64	50
<b>PLGWE 63</b>							
PLGWE 63X6X55	NEW ●	63	6	55	25	25	63
PLGWE 63X8X55	NEW ●	63	8	55	26	28	63
PLGWE 63X10X60	NEW ●	63	10	60	30	35	63
PLGWE 63X12X60	NEW ●	63	12	60	33	42	63
PLGWE 63X14X60	NEW ●	63	14	60	34	44	63
PLGWE 63X16X65	NEW ●	63	16	65	34	48	63
PLGWE 63X20X65	NEW ●	63	20	65	38	52	63
PLGWE 63X25X80	NEW ●	63	25	80	--	63	63
PLGWE 63X32X90	NEW ●	63	32	90	--	72	63
<b>PLGWE 80</b>							
PLGWE 80X6X70	NEW ●	80	6	70	27	25	80
PLGWE 80X8X70	NEW ●	80	8	70	28	28	80
PLGWE 80X10X70	NEW ●	80	10	70	29	35	80
PLGWE 80X12X70	NEW ●	80	12	70	31	42	80
PLGWE 80X16X70	NEW ●	80	16	70	32	48	80
PLGWE 80X20X70	NEW ●	80	20	70	35	52	80
PLGWE 80X25X80	NEW ●	80	25	80	50	64	80
PLGWE 80X32X80	NEW ●	80	32	80	50	72	80
PLGWE 80X40X110	NEW ●	80	40	110	--	80	80

## Accessori e Ricambi | Accessories & Spare Parts

	Codice Code	Pagina Page
<b>01 MANDRINO A CAMBIO RAPIDO   QUICK CHANGE TAPPING CHUCK</b> Standard	WEMS	p. 284
<b>02 RIDUZIONI PER ATTACCO WELDON   REDUCTIONS FOR WELDON HOLDERS</b> Standard	RWE	p. 282
<b>03 PROLUNGHE WELDON PER PORTA PINZE ER   WELDON EXTENSIONS FOR ER COLLET CHUCKS</b> Standard	PGWE	p. 206
<b>04 VITE DI BLOCCAGGIO   CLAMPING SCREW</b> Standard	SWE ..	p. 280



01



02



03



04

POLYGONAL

PLGFI

PORTAFRESE FISSI (DIN 6357)  
SHELL END MILL HOLDERS (DIN 6357)

POLYGONAL

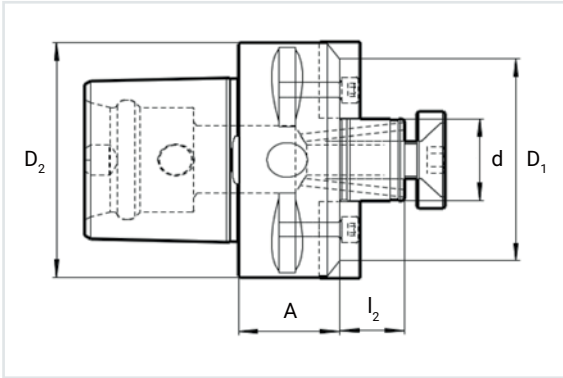

Dettagli tecnici | Technical details

Applicazione | Application

Per frese con scanalatura trasversale  
For end mills with cross groove

Grado di bilanciatura | Degree of balancing

G 6.3 15.000 giri/min | G 6.3 15.000 rpm

Run Out

Max. 8 µm

Accessori forniti | Accessories provided

Con due chiavette di trascinamento fisse e vite di bloccaggio DIN 6367  
With two fixed drive keys and clamping screw DIN 6367

Elenco Accessori e Ricambi a richiesta  
List of Accessories & Spare parts on request

Vedi pagina a fianco | See opposite page

Codice d'ordine  
Order Code STATUS

C	d	A	l <sub>2</sub>	D	D <sub>2</sub>
40	16	32	11	32	40
40	22	25	16	40	40
50	16	35	11	32	50
50	22	25	16	50	50
50	27	25	18	56	50

PLGFI 40

PLGFI 40X16X32	NEW ●
PLGFI 40X22X25	NEW ●

PLGFI 50

PLGFI 50X16X35	NEW ●
PLGFI 50X22X25	NEW ●
PLGFI 50X27X25	NEW ●

La gamma prosegue nella pagina successiva | The range continues on the next page >>

Codice d'ordine Order Code	STATUS	C	d	A	l <sub>2</sub>	D	D <sub>2</sub>
<b>PLGFI 50</b>							
PLGFI 50X32X40	NEW ●	50	32	40	20	63	50
<b>PLGFI 63</b>							
PLGFI 63X16X40	NEW ●	63	16	40	11	32	63
PLGFI 63X22X25	NEW ●	63	22	25	16	55	63
PLGFI 63X27X25	NEW ●	63	27	25	18	63	63
PLGFI 63X32X25	NEW ●	63	32	25	20	63	63
<b>PLGFI 80</b>							
PLGFI 80X16X50	NEW ●	80	16	50	11	32	80
PLGFI 80X22X30	NEW ●	80	22	30	16	55	80
PLGFI 80X27X30	NEW ●	80	27	30	18	65	80
PLGFI 80X32X30	NEW ●	80	32	30	20	80	80
PLGFI 80X40X30	NEW ●	80	40	30	23	80	80

POLYGONAL

## Accessori e Ricambi | Accessories & Spare Parts

	Codice Code	Pagina Page
<b>01 CHIAVE DI BLOCCAGGIO   CLAMPING WRENCH</b>		
Standard	CVCR	p. 279
<b>02 VITE DI BLOCCAGGIO   CLAMPING SCREW</b>		
Standard	VTGR	p. 281
<b>03 PROLUNGHE PER PORTA FRESE   EXTENSIONS FOR SHELL END MILLS HOLDERS</b>		
Standard	PRFI	p. 212



01



02



03

PLGIX

PORTAPUNTE A FISSAGGIO MECCANICO  
INDEXABLE DRILL HOLDERS

POLYGONAL

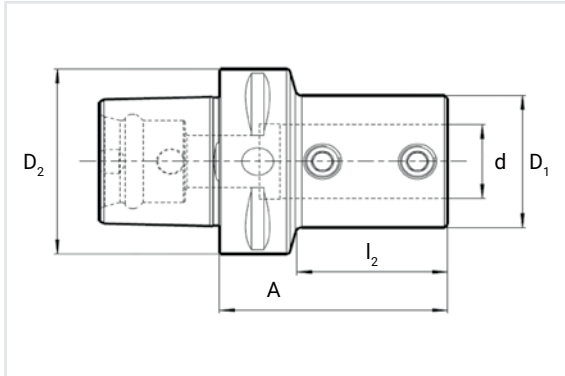

Dettagli tecnici | Technical details

Applicazione | Application

Per corpo punta a fissaggio meccanico con codolo cilindrico secondo norma DIN 9766.  
For index drill with cylindrical shank according to DIN 9766 standard.

Grado di bilanciatura | Degree of balancing

G 6.3 15.000 giri/min | G 6.3 15.000 rpm

Run Out

-

Accessori forniti | Accessories provided

N° 2 viti | No 2 screws

Elenco Accessori e Ricambi a richiesta  
List of Accessories & Spare parts on request

-

Codice d'ordine  
Order Code

STATUS

C      d      A      l<sub>2</sub>      D      D<sub>2</sub>

PLGIX 63

PLGIX 63X16X70	NEW ●
PLGIX 63X20X70	NEW ●
PLGIX 63X25X72	NEW ●
PLGIX 63X32X75	NEW ●

63	16	70	41	36	63
63	20	70	42	40	63
63	25	72	48	45	63
63	32	75	50	52	63



## PLGMS

### PORTA MASCHI TAPPING CHUCKS

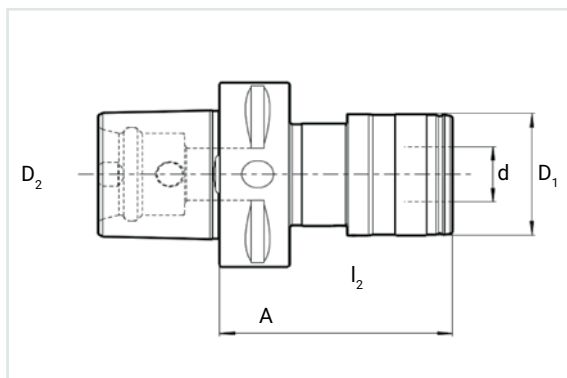

POLYGONAL

#### Dettagli tecnici | Technical details

Applicazione   Application
Grado di bilanciatura   Degree of balancing
Run Out
Accessori forniti   Accessories provided
Elenco Accessori e Ricambi a richiesta List of Accessories & Spare parts on request

Per bussole porta maschio a cambio rapido con compensazione assiale For quick change tapping chuck with axial compensation
G 6.3 8.000 giri/min   G 6.3 8.000 rpm
-
-
Vedi pagina 170   See page 170

Codice d'ordine Order Code	STATUS
-------------------------------	--------

<b>PLGMS 40</b>
PLGMS 40X1 <span style="float: right;">NEW ●</span>

<b>PLGMS 50</b>
PLGMS 50X1 <span style="float: right;">NEW ●</span>
PLGMS 50X2 <span style="float: right;">NEW ●</span>

C	Tipo Type	d	A	D	M
40	1	19	68	41	M3-12
50	1	19	68	41	M3-12
50	2	31	91	60	M8-20

La gamma prosegue nella pagina successiva | The range continues on the next page >>

Codice d'ordine Order Code	STATUS	C	Tipo Type	d	A	D	M
<b>PLGMS 63</b>							
PLGMS 63X1	NEW ●	63	1	19	73	41	M3-12
PLGMS 63X2	NEW ●	63	2	31	97	60	M8-20
PLGMS 63X3	NEW ●	63	3	48	146	86	M14-33
<b>PLGMS 80</b>							
PLGMS 80X2	NEW ●	80	2	31	94	60	M8-20

**Accessori e Ricambi | Accessories & Spare Parts**

	Codice Code	Pagina Page
<b>01 PINZE CON FRIZIONE   TAPPING COLLETS WITH CLUTCH</b>		
Standard	PZCFR	p. 242
<b>02 PINZE SENZA FRIZIONE   TAPPING COLLETS WITHOUT CLUTCH</b>		
Standard	PZSFR	p. 244



01



02

## PLGSL

### SEMI LAVORATO BLANK BARS

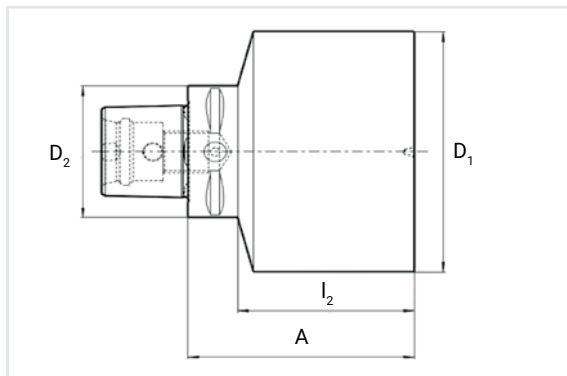

POLYGONAL

#### Dettagli tecnici | Technical details

Applicazione | Application

Per la produzione di mandrini speciali  
For the production of special tool holders

Codice d'ordine  
Order Code

STATUS

C      A      I<sub>2</sub>      D      D<sub>2</sub>

#### PLGSL 40

PLGSL 40X63X165

NEW ●

40      165      145      63      40

#### PLGSL 50

PLGSL 50X50X150

NEW ●

50      150      130      50      50

#### PLGSL 63

PLGSL 63X63X180

NEW ●

63      180      158      63      63

#### PLGSL 80

PLGSL 80X80X200

NEW ●

80      200      170      80      80



**p. 174-175**

## 2080ER

Portapinze ER  
(DIN 6499)  
Collet Chucks ER  
(DIN 6499)



**p. 176-177**

## 2080OZ

Portapinze OZ  
(DIN 6388)  
Collet Chuck OZ  
(DIN 6388)



**p. 178-180**

## 2080WE

Attacco Weldon  
Weldon Holders



**p. 181-182**

## 2080FI

Portafrese Fissi  
(DIN 6357)  
Shell End Mill Holders  
(DIN 6357)



**p. 183-184**

## 2080AC

Portafrese Combinati  
(DIN 6358)  
Combi Shell End Mill Holders  
(DIN 6358)



**p. 185**

## 2080AS

Portapunte  
Autoserranti Standard  
Standard  
Drill Chucks



**NEW**

**p. 186-187**

## 2080DS

Portapunte Autoserranti  
Alta Precisione  
High Precision  
Drill Chucks



**p. 188-189**

## 2080MS

Porta Maschi  
Tapping Chucks



**p. 190-191**

## 2080CM

Attacco Cono Morse  
per Punte (DIN 6383)  
Morse Taper  
for Drills (DIN 6383)

# DIN 2080

Indice di sezione | Section Index



p. 192-193

## 2080MK

Attacco Cono Morse  
per Frese (DIN 6364)  
Morse Taper  
for End Mills (DIN 6364)



p. 194-195

## 2080D

Attacco Conico  
(DIN 238)  
Taper Shafts  
(DIN 238)



NEW

p. 196

## 2080MR

Mandrini di Riduzione  
Reduction Arbor



NEW

p. 197

## 2080SL

Semi Lavorato  
Blank Bars

## 2080ER

### PORTAPINZE ER (DIN 6499) COLLET CHUCKS ER (DIN 6499)

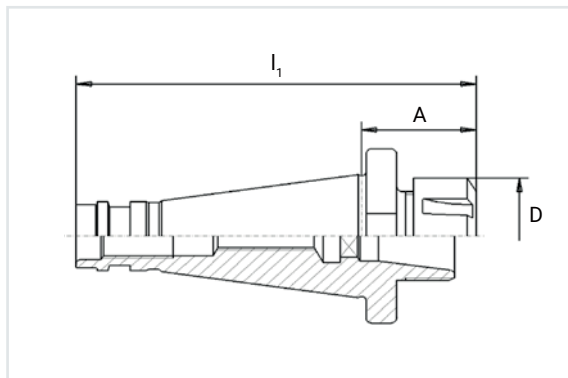

DIN 2080

#### Dettagli tecnici | Technical details

Applicazione | Application

Per utensili con codolo cilindrico in differenti tolleranze  
For tools with cylindrical shank in different tolerances

Forma | Form

-

Grado di bilanciatura | Degree of balancing

-

Run Out

Max. 5 µm

Accessori forniti | Accessories provided

Ghiera standard inclusa | Clamp not included

Elenco Accessori e Ricambi a richiesta  
List of Accessories & Spare parts on request

Vedi pagina a fianco | See opposite page

Codice d'ordine  
Order Code

STATUS

#### 2080ER 30

2080ER 30X16X42	NEW ●
2080ER 30X25X50	●
2080ER 30X32X50	●

#### 2080ER 40

2080ER 40X16X50	●
2080ER 40X25X50	●

SK	ER	A	l <sub>1</sub>	D	Gamma Range
30	16	42	110	32	1-10mm
30	25	50	119	42	2-16mm
30	32	50	119	50	2-20mm
40	16	50	143	32	2-16mm
40	25	50	143	42	2-20mm

La gamma prosegue nella pagina successiva | The range continues on the next page >>

Codice d'ordine Order Code	STATUS	SK	ER	A	I <sub>1</sub>	D	Gamma Range
<b>2080ER 40</b>							
2080ER 40X32X45	■	40	32	45	153	50	2-20mm
2080ER 40X32X50	NEW ●	40	32	50	143	50	3-30mm
2080ER 40X40X80	●	40	40	80	173	63	6-34mm
<b>2080ER 50</b>							
2080ER 50X25X60	●	50	25	60	187	42	2-20mm
2080ER 50X32X70	●	50	32	70	197	50	3-30mm
2080ER 50X40X80	●	50	40	80	207	63	6-34mm

■ Fino ad esaurimento scorte | Till stocks last

## Accessori e Ricambi | Accessories & Spare Parts

	Codice Code	Pagina Page
<b>01 PINZE ER   ER COLLETS</b>		
Standard	PZER	p. 216
Ultra precise   High precision	ERUP	p. 223
Vulcanizzate   Rubber sealed collets	ERVU	p. 229
Con quadro interno   With internal square	PZSQ	p. 233
A tenuta con fori di lubrificazione   Externally cooled collets	PZERJ	p. 236
<b>02 GHIERA DI BLOCCAGGIO ER   ER CLAMP NUT</b>		
Standard	GERB	p. 256
Bilanciata   Balanced	GERC	p. 256
Per forte serraggio   For high clamping power	GERD	p. 257
Con anello di tenuta   With sealing disk	GERE	p. 257
Con anello di tenuta a step di 0.5 mm   With sealing disk in 0.5 mm steps	GERF	p. 257
<b>03 CHIAVE DI BLOCCAGGIO   ER WRENCH CLAMP</b>		
Standard	CVER	p. 277
<b>04 TIRANTI   PULL STUDS</b>		
Senza foro di lubrificazione   Without bore	2080T	p. 269
<b>05 PROLUNGHE CILINDRICHE PER PORTA PINZE ER   CYLINDRICAL EXTENSIONS FOR ER COLLET CHUCKS</b>		
Standard	PGCL	p. 202



01



02



03



04



05

## 2080OZ

### PORTAPINZE OZ (DIN 6388) COLLET CHUCKS OZ (DIN 6388)

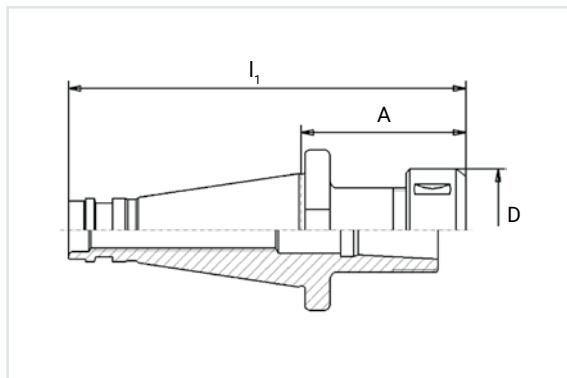

DIN 2080

#### Dettagli tecnici | Technical details

Applicazione | Application

Per utensili con codolo cilindrico in differenti tolleranze  
For tools with cylindrical shank in different tolerances

Forma | Form

-

Grado di bilanciatura | Degree of balancing

-

Run Out

Max. 5 µm

Accessori forniti | Accessories provided

Ghiera standard inclusa | Clamp not included

Elenco Accessori e Ricambi a richiesta  
List of Accessories & Spare parts on request

Vedi pagina a fianco | See opposite page

Codice d'ordine  
Order Code

STATUS

SK	OZ	A	I <sub>1</sub>	D	Gamma Range
----	----	---	----------------	---	-------------

#### 2080OZ 30

2080OZ 30X16X50	●
2080OZ 30X25X80	●

30	16	50	118	43	2-16mm
30	25	80	148	60	2-25mm

#### 2080OZ 40

2080OZ 40X16X70	●
2080OZ 40X25X70	●
2080OZ 40X32X95	●

40	16	70	163	43	2-16mm
40	25	70	163	60	2-25mm
40	32	95	173	72	3-32mm

La gamma prosegue nella pagina successiva | The range continues on the next page >>



Codice d'ordine Order Code	STATUS	SK	OZ	A	I <sub>1</sub>	D	Gamma Range
<b>2080OZ 50</b>							
2080OZ 50X25X70	●	50	25	70	197	60	2-25mm
2080OZ 50X32X80	●	50	32	80	207	72	3-32mm

## Accessori e Ricambi | Accessories & Spare Parts

	Codice Code	Pagina Page
<b>01 PINZE OZ   OZ COLLETS</b>		
Standard	PZOZ	p. 239
<b>02 GHIERA DI BLOCCAGGIO OZ   OZ CLAMP NUT</b>		
Standard	GRID1	p. 258
Bilanciato   Balanced	GRID2	p. 258
Con canali di lubrificazione   With coolant channels	GRID3	p. 258
Con anello di tenuta   With sealing disk	GRID4	p. 258
<b>03 CHIAVE DI BLOCCAGGIO OZ   OZ WRENCH CLAMP</b>		
Standard	CVOZ	p. 278
<b>04 TIRANTI   PULL STUDS</b>		
Senza foro di lubrificazione   Without bore	2080T	p. 269



01



02



03



04

## 2080WE

### ATTACCO WELDON WELDON HOLDERS

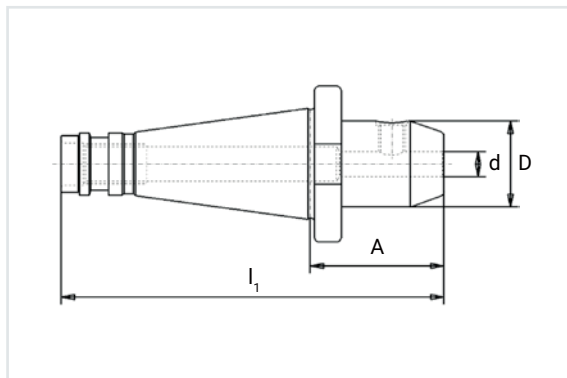

DIN 2080

#### Dettagli tecnici | Technical details

Applicazione | Application

Forma | Form

Grado di bilanciatura | Degree of balancing

Run Out

Accessori forniti | Accessories provided

Elenco Accessori e Ricambi a richiesta  
List of Accessories & Spare parts on request

Per utensili con codolo cilindrico tipo weldon secondo norma DIN 1835B.  
For tools with weldon type cylindrical shank according to DIN 1835B.

-

-

Max. 15 µm (3 x d)

Vite di bloccaggio | Clamping screw

Vedi pagina 180 | See page 180

Codice d'ordine  
Order Code

STATUS

#### 2080WE 30

2080WE 30X6X40	●
2080WE 30X8X40	●
2080WE 30X10X40	●
2080WE 30X12X40	●
2080WE 30X16X50	●
2080WE 30X20X63	●

SK	d	A	I <sub>1</sub>	D
----	---	---	----------------	---

30	6	40	108	25
30	8	40	108	28
30	10	40	108	35
30	12	40	108	42
30	16	50	118	48
30	20	63	131	52

La gamma prosegue nella pagina successiva | The range continues on the next page >>

Codice d'ordine Order Code	STATUS	SK	d	A	I <sub>1</sub>	D
<b>2080WE 40</b>						
2080WE 40X6X50	●	40	6	50	143	25
2080WE 40X8X50	●	40	8	50	143	28
2080WE 40X10X50	●	40	10	50	143	35
2080WE 40X12X50	●	40	12	50	143	42
2080WE 40X14X50	●	40	14	50	143	42
2080WE 40X16X63	●	40	16	63	156	48
2080WE 40X18X63	●	40	18	63	156	48
2080WE 40X20X63	●	40	20	63	156	52
2080WE 40X25X35	●	40	25	35	124	63
2080WE 40X25X80	●	40	25	80	173	63
2080WE 40X32X80	●	40	32	80	173	70
<b>2080WE 50</b>						
2080WE 50X6X63	●	50	6	63	190	25
2080WE 50X8X63	●	50	8	63	190	28
2080WE 50X10X63	●	50	10	63	190	35
2080WE 50X12X63	●	50	12	63	190	42
2080WE 50X14X63	●	50	14	63	190	44
2080WE 50X16X63	●	50	16	63	190	48
2080WE 50X18X63	●	50	18	63	190	48
2080WE 50X20X63	●	50	20	63	190	52
2080WE 50X25X80	●	50	25	80	207	65
2080WE 50X32X80	●	50	32	80	207	72
2080WE 50X40X90	●	50	40	90	217	90

Accessori e Ricambi alla pagina successiva | Accessories and Spare Parts on the next page >>

Accessori e Ricambi | Accessories & Spare Parts

	Codice Code	Pagina Page
<b>01 MANDRINO A CAMBIO RAPIDO   QUICK CHANGE TAPPING CHUCK</b> Standard	WEMS	p. 284
<b>02 RIDUZIONI PER ATTACCO WELDON   REDUCTIONS FOR WELDON HOLDERS</b> Standard	RWE	p. 282
<b>03 PROLUNGHE WELDON PER PORTA PINZE ER   WELDON EXTENSIONS FOR ER COLLET CHUCKS</b> Standard	PGWE	p. 206
<b>04 VITE DI BLOCCAGGIO   CLAMPING SCREW</b> Standard	SWE ..	p. 280
<b>05 TIRANTI   PULL STUDS</b> Senza foro di lubrificazione   Without bore	2080T	p. 269



01



02



03



04



05

## 2080FI

### PORTAFRESE FISSI (DIN 6357) SHELL END MILL HOLDERS (DIN 6357)

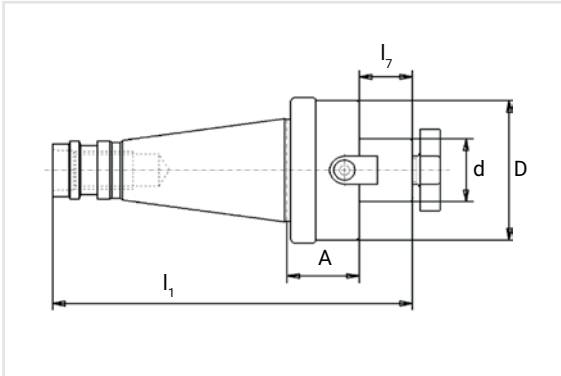

DIN 2080

#### Dettagli tecnici | Technical details

Applicazione   Application	Per frese con scanalatura trasversale For end mills with cross groove
Forma   Form	-
Grado di bilanciatura   Degree of balancing	-
Run Out	Max. 8 µm
Accessori forniti   Accessories provided	Con due chiavette di trascinamento fisse e vite di bloccaggio DIN 6367 With two fixed drive keys and clamping screw DIN 6367
Elenco Accessori e Ricambi a richiesta List of Accessories & Spare parts on request	Vedi pagina 182   See page 182

Codice d'ordine Order Code	STATUS
-------------------------------	--------

2080FI 40	
2080FI 40X16X30	NEW ●
2080FI 40X22X30	●
2080FI 40X27X30	●
2080FI 40X32X30	●
2080FI 40X40X30	●

SK	d	A	l <sub>1</sub>	l <sub>7</sub>	D
40	16	30	142	17	38
40	22	30	142	19	48
40	27	30	144	21	58
40	32	30	147	24	78
40	40	30	150	27	89

La gamma prosegue nella pagina successiva | The range continues on the next page >>

Codice d'ordine Order Code	STATUS	SK	d	A	l <sub>1</sub>	l <sub>7</sub>	D
<b>2080FI 50</b>							
2080FI 50X22X35	●	50	22	35	181	19	48
2080FI 50X27X35	●	50	27	35	183	21	58
2080FI 50X32X40	●	50	32	40	191	24	78
2080FI 50X40X33	●	50	40	33	187	27	89
2080FI 50X60X55	●	50	60	55	202	40	129

Accessori e Ricambi | Accessories & Spare Parts

	Codice Code	Pagina Page
<b>01 CHIAVE DI BLOCCAGGIO   CLAMPING WRENCH</b>		
Standard	CVCR	p. 279
<b>02 VITE DI BLOCCAGGIO   CLAMPING SCREW</b>		
Standard	VTCR	p. 281
<b>03 TIRANTI   PULL STUDS</b>		
Senza foro di lubrificazione   Without bore	2080T	p. 269
<b>04 PROLUNGHE PER PORTA FRESE   EXTENSIONS FOR SHELL END MILLS HOLDERS</b>		
Standard	PRFI	p. 212



01



02



03



04

## 2080AC

### PORTAFRESE COMBINATI (DIN 6358) COMBI SHELL END MILL HOLDERS (DIN 6358)

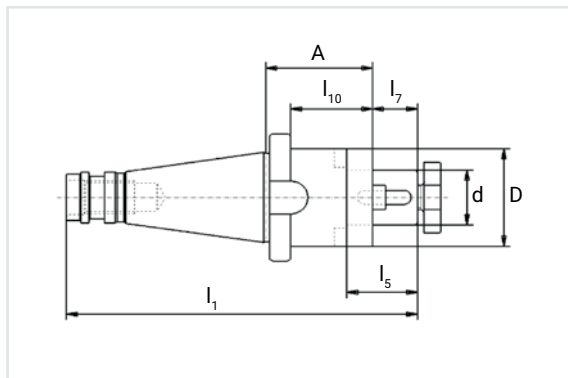

DIN 2080

#### Dettagli tecnici | Technical details

Applicazione | Application

Per frese con scanalatura longitudinale o trasversale  
For end mills with longitudinal and cross groove

Forma | Form

-

Grado di bilanciatura | Degree of balancing

-

Run Out

Max. 8  $\mu$ m

Accessori forniti | Accessories provided

Con Vite di bloccaggio DIN 6367, anello di trascinamento DIN 6366 e chiave di bloccaggio.  
With clamping screw DIN 6367, drive ring DIN 6366 and feather key.

Elenco Accessori e Ricambi a richiesta  
List of Accessories & Spare parts on request

Vedi pagina 184 | See page 184

Codice d'ordine  
Order Code

STATUS

SK	d	A	l <sub>1</sub>	l <sub>5</sub>	l <sub>7</sub>	l <sub>10</sub>	D
----	---	---	----------------	----------------	----------------	-----------------	---

#### 2080AC 30

2080AC 30X16X35	NEW ●
2080AC 30X22X35	●
2080AC 30X27X35	●
2080AC 30X32X50	●

30	16	35	120	27	17	25	32
30	22	35	122	31	19	25	40
30	27	35	124	33	21	25	48
30	32	50	142	38	24	40	58

#### 2080AC 40

2080AC 40X16X52	●
-----------------	---

40	16	52	162	27	17	40	32
----	----	----	-----	----	----	----	----

La gamma prosegue nella pagina successiva | The range continues on the next page >>

Codice d'ordine Order Code	STATUS	SK	d	A	l <sub>1</sub>	l <sub>5</sub>	l <sub>7</sub>	l <sub>10</sub>	D
<b>2080AC 40</b>									
2080AC 40X22X52	●	40	22	52	164	31	19	40	40
2080AC 40X27X52	●	40	27	52	166	33	21	40	48
2080AC 40X32X52	●	40	32	52	169	38	24	40	58
2080AC 40X40X52	●	40	40	52	172	41	27	40	70
<b>2080AC 50</b>									
2080AC 50X16X55	●	50	16	55	199	27	17	40	32
2080AC 50X22X55	●	50	22	55	201	31	19	40	40
2080AC 50X27X55	●	50	27	55	203	33	21	40	48
2080AC 50X32X55	●	50	32	55	206	38	24	40	58
2080AC 50X40X55	●	50	40	55	209	41	27	40	70

Accessori e Ricambi | Accessories & Spare Parts

	Codice Code	Pagina Page
<b>01 CHIAVE DI BLOCCAGGIO   CLAMPING WRENCH</b>		
Standard	CVCR	p. 279
<b>02 VITE DI BLOCCAGGIO   CLAMPING SCREW</b>		
Standard	VTCR	p. 281
<b>03 ANELLO DI TRASCINAMENTO   DRIVE RING</b>		
Standard	ANTR	p. 286
<b>04 TIRANTI   PULL STUDS</b>		
Senza foro di lubrificazione   Without bore	2080T	p. 269



01



02



03



04



## 2080AS

### PORTAPUNTE AUTOSERRANTI (STANDARD) DRILL CHUCKS (STANDARD)

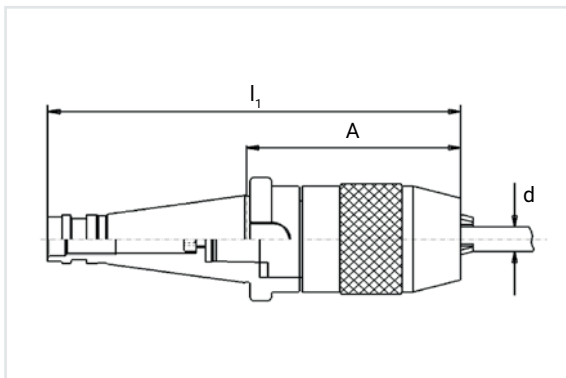

DIN 2080

#### Dettagli tecnici | Technical details

Applicazione   Application	Per punte con codolo cilindrico in differenti tolleranze For drills with cylindrical shank in different tolerances
Forma   Form	-
Grado di bilanciatura   Degree of balancing	-
Run Out	Max. 50 µm
Accessori forniti   Accessories provided	Chiave   Key
Elenco Accessori e Ricambi a richiesta List of Accessories & Spare parts on request	Tiranti (vedi pagina 260-261)   Pull Studs (see page 260-261)

Codice d'ordine Order Code	STATUS	SK	d	A	l <sub>1</sub>
<b>2080AS 40</b>					
2080AS 40X13	●	40	1-13	92	186
2080AS 40X16	●	40	3-16	110	204
<b>2080AS 50</b>					
2080AS 50X16	●	50	3-16	86	213

## 2080DS

### PORTAPUNTE AUTOSERRANTI (ALTA PRECISIONE) DRILL CHUCKS (HIGH PRECISION)

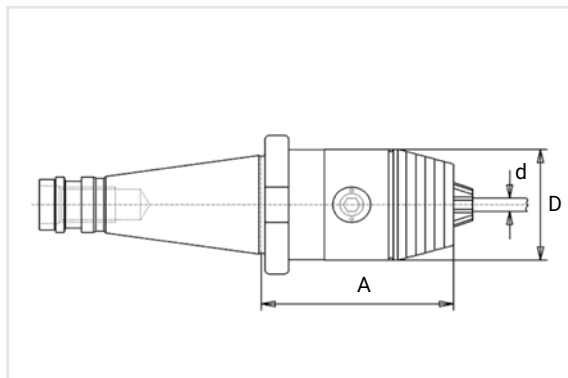

DIN 2080

#### Dettagli tecnici | Technical details

Applicazione | Application

Per punte con codolo cilindrico in differenti tolleranze  
For drills with cylindrical shank in different tolerances

Forma | Form

-

Grado di bilanciatura | Degree of balancing

-

Run Out

Max. 20 µm (3 x d)

Accessori forniti | Accessories provided

Chiave | Key

Elenco Accessori e Ricambi a richiesta  
List of Accessories & Spare parts on request

Vedi pagina a fianco | See opposite page

Codice d'ordine  
Order Code

STATUS

SK

d

A

D

Range

#### 2080DS 30

2080DS 30X8

NEW ●

30

8

60

36

0,5-8

2080DS 30X13

NEW ●

30

13

98

50

1-13

#### 2080DS 40

2080DS 40X8

NEW ●

40

8

62

36

0,5-8

2080DS 40X13

NEW ●

40

13

83

50

1-13

2080DS 40X16

NEW ●

40

16

88

57

2,5-16

La gamma prosegue nella pagina successiva | The range continues on the next page >>

Codice d'ordine Order Code	STATUS	SK	d	A	D	Range
<b>2080DS 50</b>						
2080DS 50X13	NEW ●	50	13	110	50	1-13
2080DS 50X16	NEW ●	50	16	115	57	2,5-16

## Accessori e Ricambi | Accessories & Spare Parts

	Codice Code	Pagina Page
<b>04 TIRANTI   PULL STUDS</b>		
Senza foro di lubrificazione   Without bore	2080T	p. 269



01

DIN 2080

## 2080MS

### PORTA MASCHI TAPPING CHUCKS

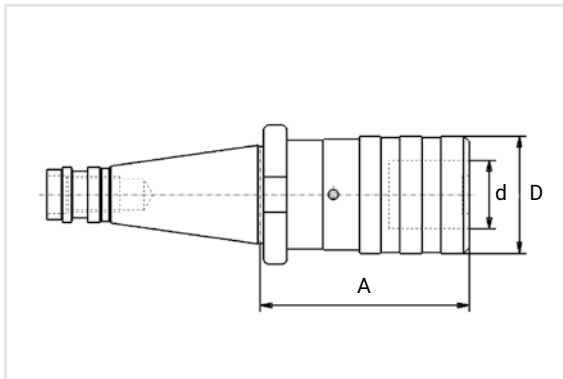

DIN 2080

#### Dettagli tecnici | Technical details

Applicazione | Application

Per bussole porta maschio a cambio rapido con compensazione assiale  
For quick change tapping chuck with axial compensation

Forma | Form

-

Grado di bilanciatura | Degree of balancing

-

Run Out

-

Accessori forniti | Accessories provided

-

Elenco Accessori e Ricambi a richiesta  
List of Accessories & Spare parts on request

Vedi pagina a fianco | See opposite page

Codice d'ordine  
Order Code

STATUS

SK	Tipo Type	d	A	D	M
----	--------------	---	---	---	---

#### 2080MS 30

2080MS 30X1	●
2080MS 30X2	●

30	1	19	51	38	M3-12
30	2	31	86	55	M8-20

#### 2080MS 40

2080MS 40X1	●
2080MS 40X2	●
2080MS 40X3	●

40	1	19	53	38	M3-12
40	2	31	77	55	M8-20
40	3	48	118	79	M14-33

La gamma prosegue nella pagina successiva | The range continues on the next page >>

Codice d'ordine Order Code	STATUS	SK	Tipo Type	d	A	D	M
<b>2080MS 50</b>							
2080MS 50X1	●	50	1	19	57	38	M3-12
2080MS 50X2	●	50	2	31	79	55	M8-20
2080MS 50X3	●	50	3	48	125	79	M14-33

## Accessori e Ricambi | Accessories & Spare Parts

	Codice Code	Pagina Page
<b>01 PINZE CON FRIZIONE   TAPPING COLLETS WITH CLUTCH</b>		
Standard	PZCFR	p. 242
<b>02 PINZE SENZA FRIZIONE   TAPPING COLLETS WITHOUT CLUTCH</b>		
Standard	PZSFR	p. 244
<b>03 TIRANTI   PULL STUDS</b>		
Senza foro di lubrificazione   Without bore	2080T	p. 269



01



02



03

## 2080CM

### ATTACCO CONO MORSE PER PUNTE (DIN 6383) MORSE TAPER FOR DRILLS (DIN 6383)

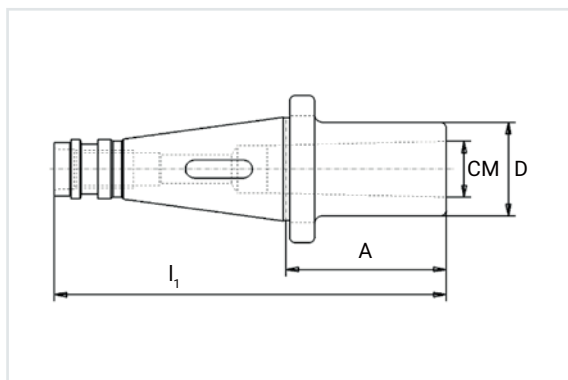

#### Dettagli tecnici | Technical details

Applicazione | Application

Per punte attacco cono morse  
For drills with cono morse shank

Forma | Form

-

Grado di bilanciatura | Degree of balancing

-

Run Out

Max. 10 µm

Accessori forniti | Accessories provided

-

Elenco Accessori e Ricambi a richiesta  
List of Accessories & Spare parts on request

Vedi pagina a fianco | See opposite page

Codice d'ordine  
Order Code

STATUS

SK

CM

A

I<sub>1</sub>

D

#### 2080CM 30

2080CM 30X1X50 ●

2080CM 30X2X50 ●

2080CM 30X3X75 NEW ●

30 1 50 118 25

30 2 50 118 32

30 3 75 143 40

#### 2080CM 40

2080CM 40X1X50 ●

2080CM 40X2X50 ●

40 1 50 143 25

40 2 50 143 32

La gamma prosegue nella pagina successiva | The range continues on the next page >>

Codice d'ordine Order Code	STATUS	SK	CM	A	I <sub>1</sub>	D
<b>2080CM 40</b>						
2080CM 40X3X65	●	40	3	65	158	40
2080CM 40X4X95	●	40	4	95	188	48
<b>2080CM 50</b>						
2080CM 50X1X45	●	50	1	45	172	25
2080CM 50X2X50	●	50	2	50	177	32
2080CM 50X3X65	●	50	3	65	192	40
2080CM 50X4X70	●	50	4	70	197	48
2080CM 50X5X105	●	50	5	105	232	63

## Accessori e Ricambi | Accessories & Spare Parts

	Codice Code	Pagina Page
<b>01 TIRANTI   PULL STUDS</b>		
Senza foro di lubrificazione   Without bore	2080T	p. 269
<b>02 TENONE DI ESPULSIONE   TANGS TO SCREW IN</b>		
Standard	TEVT	p. 273



01



02

## 2080MK

### ATTACCO CONO MORSE PER FRESE (DIN 6364) MORSE TAPER FOR END MILLS (DIN 6364)

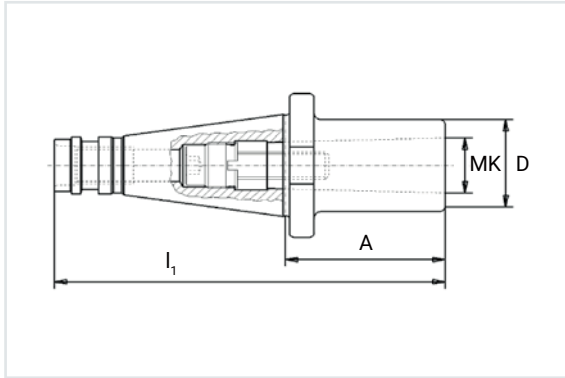

DIN 2080

#### Dettagli tecnici | Technical details

Applicazione | Application

Per frese attacco cono morse  
For end mills with cono morse shank

Forma | Form

-

Grado di bilanciatura | Degree of balancing

-

Run Out

Max. 10 µm

Accessori forniti | Accessories provided

Vite di bloccaggio | Clamping screw

Elenco Accessori e Ricambi a richiesta  
List of Accessories & Spare parts on request

Vedi pagina a fianco | See opposite page

Codice d'ordine  
Order Code

STATUS

SK MK A I<sub>1</sub> D

#### 2080MK 40

2080MK 40X1X50	●
2080MK 40X2X50	●
2080MK 40X3X65	●
2080MK 40X4X95	●

40	1	50	143	25
40	2	50	143	32
40	3	65	158	40
40	4	95	188	48

#### 2080MK 50

2080MK 50X1X60	NEW ●
----------------	-------

50	1	60	187	25
----	---	----	-----	----

La gamma prosegue nella pagina successiva | The range continues on the next page >>



Codice d'ordine Order Code	STATUS	SK	MK	A	I <sub>1</sub>	D
<b>2080MK 50</b>						
2080MK 50X2X60	●	50	2	60	187	32
2080MK 50X3X65	●	50	3	65	192	40
2080MK 50X4X65	●	50	4	65	192	48
2080MK 50X5X120	●	50	5	120	247	63

## Accessori e Ricambi | Accessories & Spare Parts

	Codice Code	Pagina Page
<b>04 TIRANTI   PULL STUDS</b>		
Senza foro di lubrificazione   Without bore	2080T	p. 269



01

DIN 2080

## 2080D

### ATTACCO CONICO (DIN 238) TAPER SHAFTS (DIN 238)

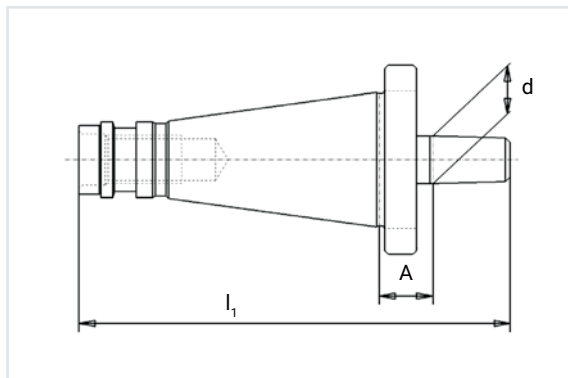

DIN 2080

#### Dettagli tecnici | Technical details

Applicazione | Application

Per mandrini DIN 238  
For toolholders DIN 238

Forma | Form

-

Grado di bilanciatura | Degree of balancing

-

Run Out

-

Accessori forniti | Accessories provided

Senza mandrino autoserrante | Without drill chuck head

Elenco Accessori e Ricambi a richiesta  
List of Accessories & Spare parts on request

Vedi pagina a fianco | See opposite page

Codice d'ordine  
Order Code

STATUS

SK

d

A

l<sub>1</sub>

#### 2080D 30

2080D 30X12	●
2080D 30X16	●

30	12	13	100
30	16	15	107

#### 2080D 40

2080D 40X12	●
2080D 40X16	●
2080D 40X18	●

40	12	15	127
40	16	17	134
40	18	17	142

La gamma prosegue nella pagina successiva | The range continues on the next page >>

Codice d'ordine Order Code	STATUS	SK	d	A	l <sub>1</sub>
<b>2080D 50</b>					
2080D 50X16	●	50	16	20	171
2080D 50X18	●	50	18	20	179

## Accessori e Ricambi | Accessories & Spare Parts

	Codice Code	Pagina Page
<b>04 TIRANTI   PULL STUDS</b>		
Senza foro di lubrificazione   Without bore	2080T	p. 269



01

DIN 2080

## 2080MR

### MANDRINI DI RIDUZIONE REDUCTION ARBOR

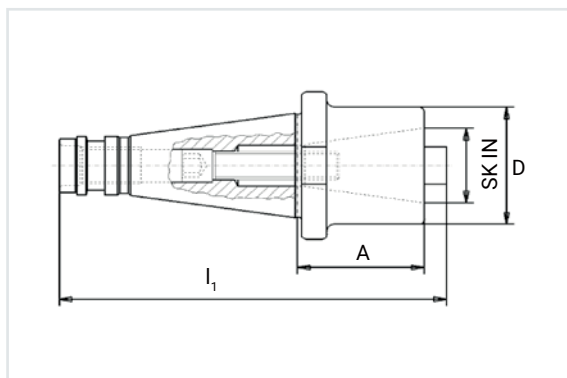

DIN 2080

#### Dettagli tecnici | Technical details

Applicazione | Application

Per riduzione cono ad elevata rastrematura SK  
For SK high taper cone reduction

Forma | Form

-

Accessori forniti | Accessories provided

Vite di bloccaggio | Clamping screw

Elenco Accessori e Ricambi a richiesta  
List of Accessories & Spare parts on request

Tiranti (vedi pagina 260-261) | Pull Studs (see page 260-261)

Codice d'ordine Order Code	STATUS
<b>2080MR 40</b>	
2080MR 40X30	NEW ●
<b>2080MR 50</b>	
2080MR 50X40	NEW ●
2080MR 50X50	NEW ●

SK Out/In	A	l <sub>1</sub>	D
40X30	50	152	50
50X40	70	190	70
50X50	97	261	97

In fase d'ordine specificare se si desidera ridurre o prolungare un cono DIN2080, DIN69871 o MAS BT.  
When ordering please give information whether you want to reduce or extend a taper DIN2080, DIN69871 or MAS BT.

## 2080SL

### SEMI LAVORATO BLANK BARS

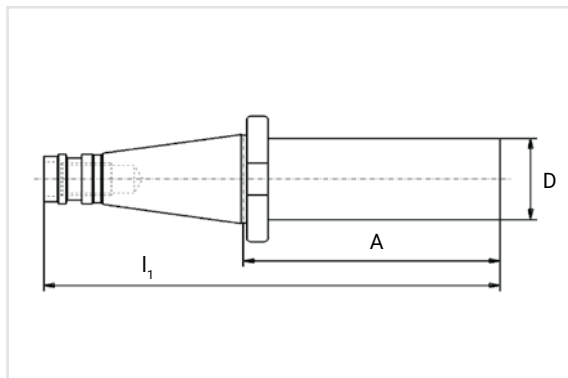

DIN 2080

#### Dettagli tecnici | Technical details

Applicazione | Application

Per la produzione di mandrini speciali  
For the production of special tool holders

Forma | Form

-

Accessori forniti | Accessories provided

-

Elenco Accessori e Ricambi a richiesta  
List of Accessories & Spare parts on request

Tiranti (vedi pagina 260-261) | Pull Studs (see page 260-261)

Codice d'ordine Order Code	STATUS	SK	A	l <sub>1</sub>	D
<b>2080SL 40</b>					
2080SL 40X40.5X160	NEW ●	40	160	253	40.5
2080SL 40X63X250	NEW ●	40	250	343	63
<b>2080SL 50</b>					
2080SL 50X97X315	NEW ●	50	315	442	97